

## RIELLO 40 N SERIES

The Riello 40 N series of one stage heavy oil burners, is a complete range of products developed to respond to any request for the use of heavy oil in heating systems and light industrial processes. The Riello 40 N series is available in two different models, with an output ranging from 34 to 217 kW, divided into two basic structures.

All the models use many components designed by Riello for the Riello 40 series but are fitted with special components for heavy oil combustion.

The high quality level guarantees safe working.

In developing these burners, special attention has been paid to reducing noise, to the ease of installation and adjustment, to reducing the size in order to facilitate installation in any kind of boiler on the market.

All the models are conform to EMC European Directives, for Low Voltage and Machinery.

All the Riello 40 N burners are tested before leaving the factory.



N 10	34 ÷ 102 kW
N 20	102 ÷ 217 kW

### FIRING RATES

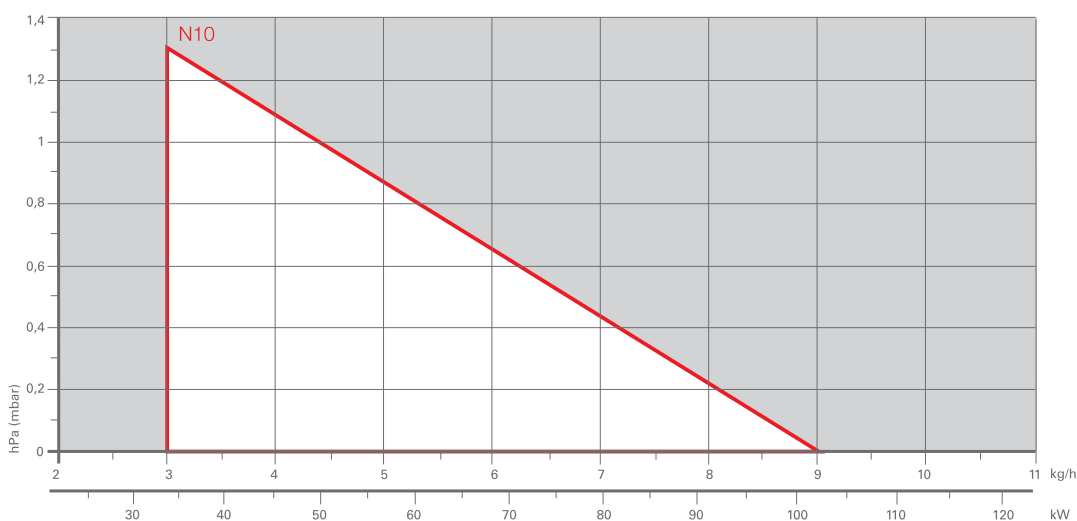

Useful working field for choosing the burner

Test conditions  
 Temperature: 20°C  
 Pressure: 1013,5 mbar  
 Altitude: 0 m a.s.l.

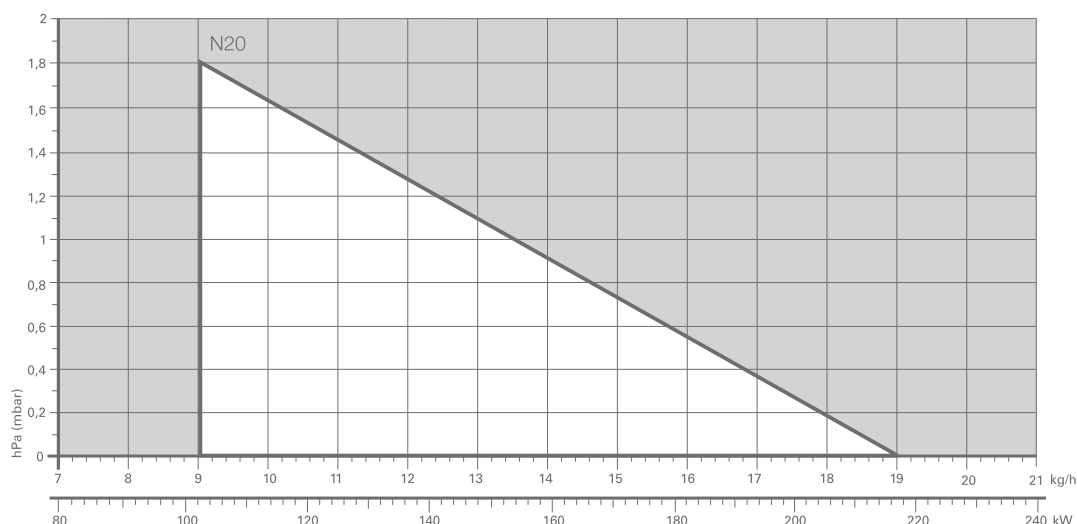

# One Stage Heavy Oil Burners

## RIELLO 40 N SERIES

### Overall dimensions (mm)

#### BURNER

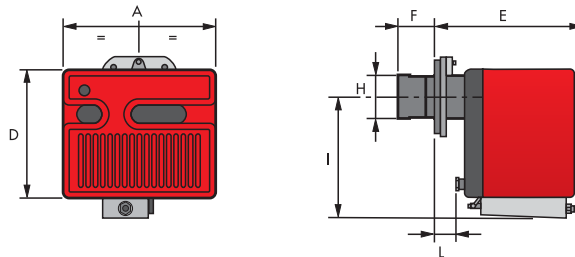

MODEL	A	D	E	F	H	I	L
► N10	305	262	275	108	105	258	25
► N20	350	298	295	118	125	280	35

#### BURNER - BOILER MOUNTING FLANGE

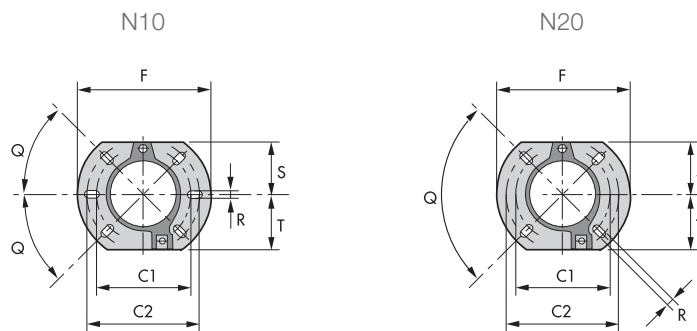

MODEL	C1	C2	F	Q	R	S	T
► N10	140	170	189	45°	11	83	83
► N20	160	190	213	90°	11	99	99

#### PACKAGING

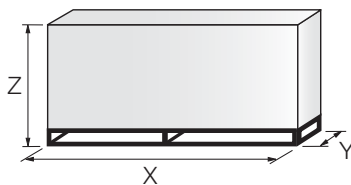

MODEL	X	Y	Z	kg
► N10	395	307	375	26
► N20	425	352	410	29

## RIELLO 40 N SERIES

# Specification

## DESIGNATION OF SERIES

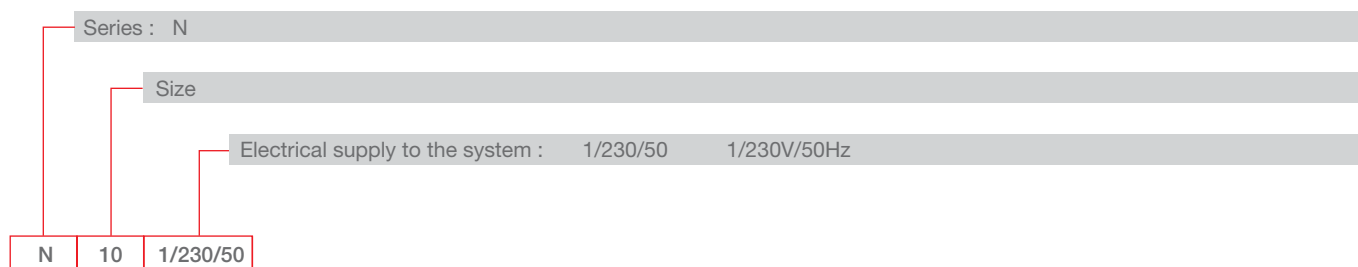

## STATE OF SUPPLY

Completely automatic monobloc heavy oil burners, one stage operation, made up to:

- Fan with forward curve blades
- Metallic cover lined with sound-proofing material
- Metallic air damper
- Single phase electric motor 230 V, 50 Hz
- Combustion head fitted with:
  - stainless steel head cone, resistant to high temperatures
  - ignition electrodes
  - flame stability disk
- Geared pump for fuel supply, fitted with:
  - filter
  - pressure regulator
  - attachments for fitting a pressure gauge and vacuum meter
  - internal by-pass for preparing for single-pipe installations
- Heavy oil preheater
- Heavy oil filter into the preheater
- Heavy oil manometer
- Heavy oil thermometer
- Heavy oil protection valve
- Heavy oil outlet valve
- Adjustment thermostat with probe
- Thermostat for fuel low temperature
- Fuel feed solenoid valve incorporated in the pump
- Terminal block for electrical links
- Photocell for flame detection
- Electronic flame control equipment
- Electronic transformer
- Protective filter against radio interference
- IP X0D (IP 40) protection level.

### Standard equipment:

- Heavy oil nozzle
- Two flexible pipes with seal for connection to the heavy oil supply line
- Two nipples for connection to the pump
- Flange, screws and nuts for fixing
- Thermal gasket
- Hinge kit
- Grommet
- Instruction handbook for installation, use and maintenance
- Spare parts catalogue.

# One Stage Heavy Oil Burners

## RIELLO 40 N SERIES

### Available models

CODE	MODEL		HEAT OUTPUT		TOTAL ELECTRICAL POWER (kW)	CERTIFICATION	NOTE
			(kW)	(kg/h)			
3412016	N10	1/230/50	34 - 102	3 - 9	1,1	-	(1)
3412816	N20	1/230/50	102 - 217	9 - 19	1,8	-	(1)

Net calorific value: 11,3 kWh/kg; 9720 kcal/kg - Max Viscosity at 50°C: 5°E (38 mm²/s, cSt), Type MEDIUM HEAVY OIL / USA n° 4.  
 (1) Austrian version.

## Burner accessories

### Cartridge filter



BURNER	KIT CODE
► N10 - N20	3004588

### Self-cleaning filter



BURNER	KIT CODE
► N10 - N20	3000861

## PRESS N SERIES

The PRESS N series of burners covers a firing range from 171 to 1140 kW and they have been designed for use in civil installations of average dimensions, like building areas and large apartment groups or for use in industrial applications, like small or medium plants.

Operation is two stage; a servomotor adjust automatically air damper opening, to obtain the right air delivery on both stage. The burners are fitted with a microprocessor control panel which supplies indication of operation and diagnosis of fault cause.

The combustion head, that can be set on the basis of required output, allows optimal performance ensuring good combustion and reducing fuel consumption and is available in two different length to be selected on the basis of specific application requirements.

In basic version the burners are supplied for use with heavy oil 7°E viscosity, but they can be supplied with higher viscosity oil with a specific heaters kit.

Simplified maintenance is achieved by the slide bar system, which allows easy access to all of the essential components of the combustion head.



<b>PRESS 30 N</b>	85/171 ÷ 342 kW
<b>PRESS 45 N</b>	114/205 ÷ 513 kW
<b>PRESS 60 N</b>	171/342 ÷ 684 kW
<b>PRESS 100 N</b>	285/490 ÷ 1140 kW

## FIRING RATES

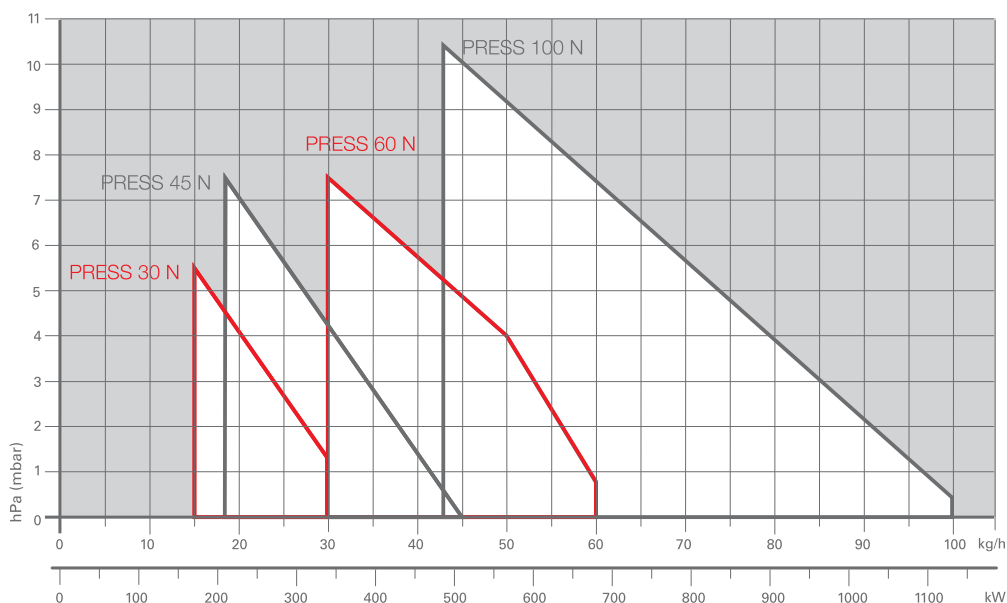

Useful working field for choosing the burner

Test conditions conforming to EN267  
 Temperature: 20°C  
 Pressure: 1013,5 mbar  
 Altitude: 0 m a.s.l.

# Two Stage Heavy Oil Burners

## PRESS N SERIES

### Overall dimensions (mm)

#### BURNER

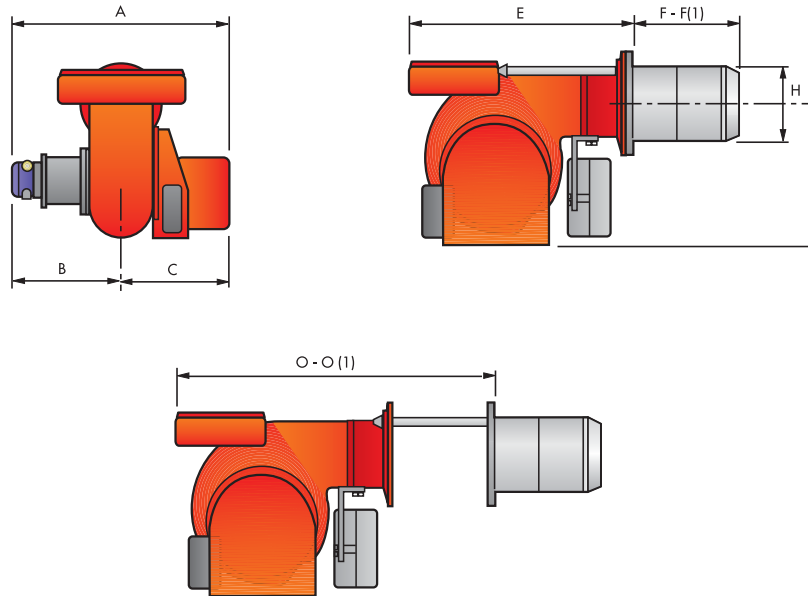

MODEL	A	B	C	E	F - F(1)	H	I	O - O(1)
► PRESS 30 N	625	335	290	625	185 - 320	161	305	905 - 1080
► PRESS 45 N	625	335	290	625	235 - 370	161	305	925 - 1100
► PRESS 60 N	625	335	290	660	245 - 400	172	335	940 - 1115
► PRESS 100 N	625	335	290	710	250 - 410	195	370	1010 - 1195

(1) Length with extended combustion head

#### BURNER - BOILER MOUNTING FLANGE

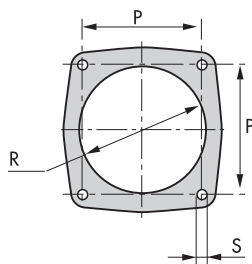

MODEL	P	R	S
► PRESS 30 N	160	170	M 10
► PRESS 45 N	160	170	M 10
► PRESS 60 N	160	180	M 10
► PRESS 100 N	195	205	M 12

#### PACKAGING

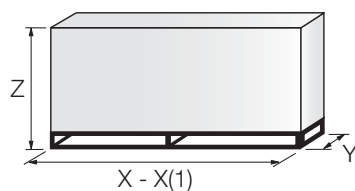

MODEL	X - X(1)	Y	Z	kg
► PRESS 30 N	880 - 1015	690	622	84
► PRESS 45 N	880 - 1015	690	622	84
► PRESS 60 N	925 - 1095	760	652	87
► PRESS 100 N	985 - 1145	790	652	104

(1) Length with extended combustion head

# Two Stage Heavy Oil Burners

## PRESS N SERIES

**RIELLO**

# Specification

## DESIGNATION OF SERIES

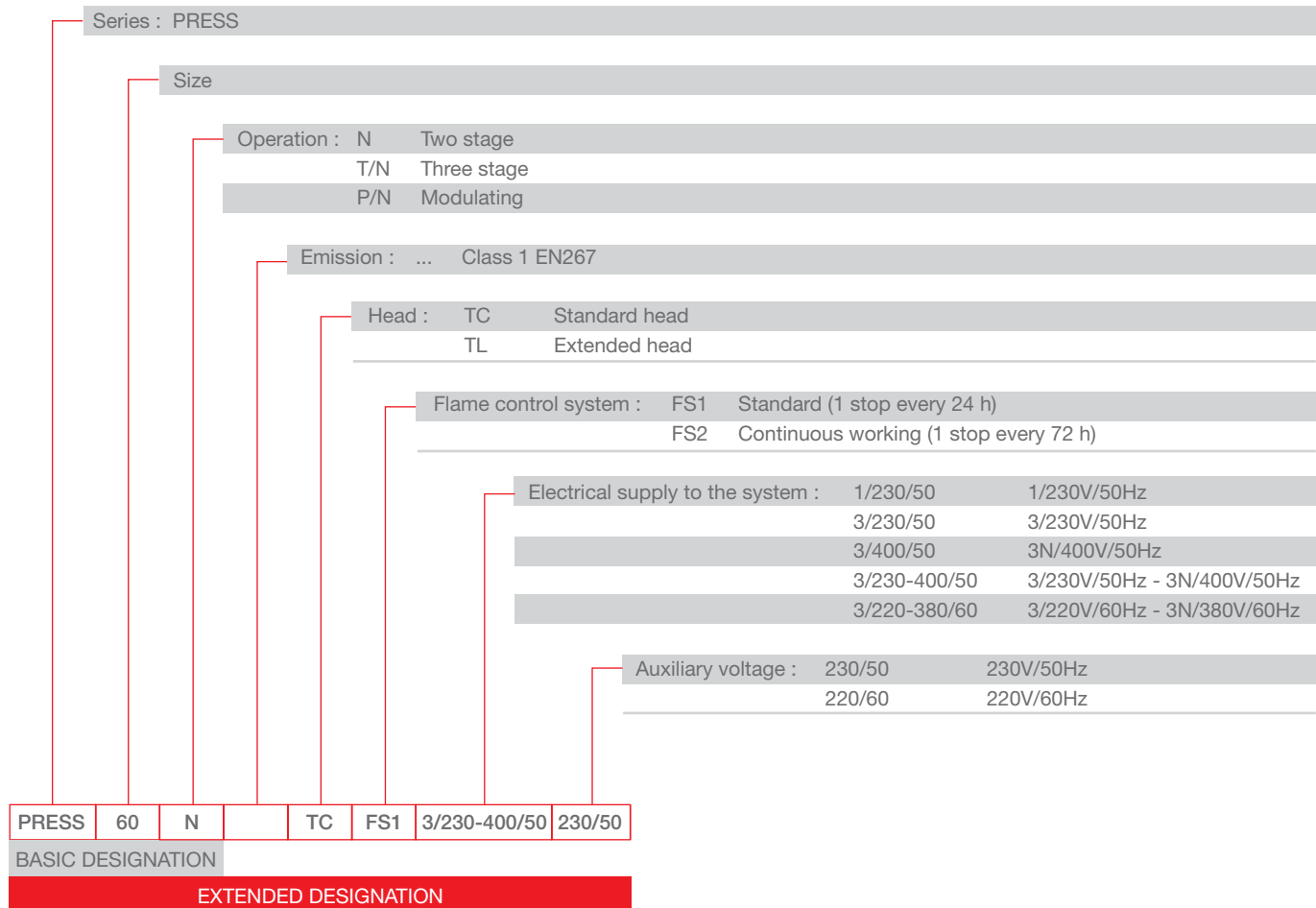

HEAVY OIL

# Two Stage Heavy Oil Burners

## PRESS N SERIES

### Specification

#### STATE OF SUPPLY

Monoblock forced draught heavy oil burner, two stage operation, made up of:

- Air suction circuit
- Fan with forward curved blades
- Air dampers for air setting controlled by a servomotor
- Starting motor at 2850 rpm
- Combustion head, fitted with:
  - stainless steel end cone, resistant to corrosion and high temperatures
  - ignition electrodes
  - flame stability disk
- Gears pump for high pressure fuel supply, fitted with:
  - filter
  - pressure regulator
  - connections for installing a pressure gauge and vacuumeter
  - internal by-pass for single pipe installation
- Valve unit with a double oil safety valve on the output circuit;
- Oil preheater provided with chance of a thermometer application for temperature control;
- Servomotor for air damper regulation;
- Photocell for flame detection;
- Microprocessor-based burner safety control box, with diagnostic function
- Flame inspection window
- Slide bars for easier installation and maintenance
- Protection filter against radio interference
- IP X0D (IP 40) protection level.

#### Standard equipment:

- 2 flexible hoses for pipe connection
- 2 gaskets for flexible hoses
- 2 nipples for flexible hoses
- 1 thermal insulation screen
- 4 screws for fixing the burner flange to the boiler
- 2 nozzles (see table of available burner model)
- 2 extensions for bars (for long head version)
- Instruction handbook for installation, use and maintenance
- Spare parts catalogue.



# Two Stage Heavy Oil Burners

## PRESS N SERIES

**RIELLO**

### Available models

CODE	MODEL					HEAT OUTPUT		TOTAL ELECTRICAL POWER (kW)	CERTIFICATION	NOTE
						(kW)	(kg/h)			
3433723	PRESS 30 N	TC	FS1	1/230/50	230/50	85/171-342	7,5/15-30	3,4	-	(1)
3433724	PRESS 30 N	TL	FS1	1/230/50	230/50	85/171-342	7,5/15-30	3,4	-	(1)
3433785	PRESS 30 N	TC	FS1	3/220-380/60	220/60	85/171-342	7,5/15-30	3,7	-	
3433786	PRESS 30 N	TL	FS1	3/220-380/60	220/60	85/171-342	7,5/15-30	3,7	-	
3434523	PRESS 45 N	TC	FS1	3/230-400/50	230/50	114/205-513	10/18-45	3,6	-	(1)
3434524	PRESS 45 N	TL	FS1	3/230-400/50	230/50	114/205-513	10/18-45	3,6	-	(1)
3434585	PRESS 45 N	TC	FS1	3/220-380/60	220/60	114/205-513	10/18-45	3,7	-	
3434586	PRESS 45 N	TL	FS1	3/220-380/60	220/60	114/205-513	10/18-45	3,7	-	
3434923	PRESS 60 N	TC	FS1	3/230-400/50	230/50	171/342-684	15/30-60	5,5	-	(1)
3434924	PRESS 60 N	TL	FS1	3/230-400/50	230/50	171/342-684	15/30-60	5,5	-	(1)
3434985	PRESS 60 N	TC	FS1	3/220-380/60	220/60	171/342-684	15/30-60	5,8	-	
3434986	PRESS 60 N	TL	FS1	3/220-380/60	220/60	171/342-684	15/30-60	5,8	-	
3435923	PRESS 100 N	TC	FS1	3/230-400/50	230/50	285/490-1140	25/43-100	9,0	-	(1)
3435924	PRESS 100 N	TL	FS1	3/230-400/50	230/50	285/490-1140	25/43-100	9,0	-	(1)
3435985	PRESS 100 N	TC	FS1	3/220-380/60	220/60	285/490-1140	25/43-100	9,0	-	
3435986	PRESS 100 N	TL	FS1	3/220-380/60	220/60	285/490-1140	25/43-100	9,0	-	

(1) 2 nozzles as standard equipment.

Net calorific value: 11,16 kWh/kg; 9600 kcal/kg - Max Viscosity at 50°C: 7°E (50 mm<sup>2</sup>/s, cSt), Type MEDIUM HEAVY OIL / USA n° 4.

The burners of PRESS series are in according to 89/336 (2004/108) - 73/23 (2006/95) EC Directive and EN 267 Norm.

# Two Stage Heavy Oil Burners

## PRESS N SERIES

### Burner accessories

#### Extended head kit

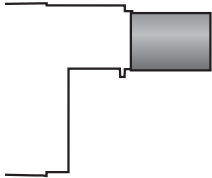

“Standard head” burners can be transformed into “extended head” versions, by using the special kit. The KITS available for the various burners, giving the original and the extended lengths, are listed below.

BURNER	STANDARD HEAD LENGTH (mm)	EXTENDED HEAD LENGTH (mm)	KIT CODE
PRESS 30 N	185	320	20015280
PRESS 60 N	245	400	3092198

#### Spacer kit



If burner head penetration into the combustion chamber needs reducing, varying thickness spacers are available, as given in the list.

BURNER	SPACER THICKNESS S (mm)	KIT CODE
► PRESS 30 N - 45 N - 60 N	142	3000755
► PRESS 100 N	142	3000802

#### Sound proofing box

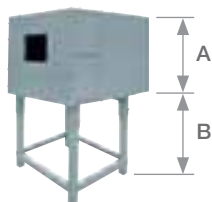

If noise emission needs reducing even further, sound-proofing boxes are available.

BURNER	BOX TYPE	A (mm)	B (mm) min-max	[dB(A)] (*)	BOX CODE
► PRESS 30 N - 45 N - 60 N - 100 N	C1/3	650	372 - 980	10	3010403

(\*) Average noise reduction according to EN 15036-1 standard

#### Self-cleaning filter



For cleaning heavy oil from dirty particles and impurities, it is equipped with a thermostatic heater for oil with 50°E viscosity at 50°C.

FILTER TYPE	FILTER CODE
► $\phi=1$ 50°E - 50°C	3000790

HEATER TYPE	HEATER CODE
► Thermostatic heater 80W	3010059

#### Heavy oil kit

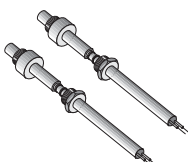

Equipped with electrical heaters, it permits the employment of PRESS N burners with fuel oil of max. viscosity 20°E at 50°C (type BUNKER B / USA n° 5).

BURNER	MAX VISCOSITY	KIT CODE
► PRESS 30 N - 45 N	20°E at 50°C	3000797
► PRESS 60 N - 100 N	20°E at 50°C	3010013

## Burner accessories

### Cartridge filter



For cleaning heavy oil from dirty particles and impurities, it is equipped with a cartridge system for oil with 7°E viscosity at 50°C.

FILTER TYPE	FILTER CODE
► Cartridge 7°E - 50°C	3005209

HEATER TYPE	HEATER CODE
► Thermo - resistance up to 30°E - 50°	3010050

### Thermostats

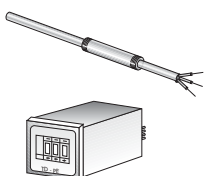

Thermostats allow heavy oil temperature control and regulation during burner operation. They are available in electronic and maximum versions.

BURNER	THERMOSTAT TYPE	THERMOSTAT CODE
► PRESS 30 N - 45 N - 60 N - 100 N	Electronic	3000799
► PRESS 30 N - 45 N - 60 N - 100 N	Maximum	3000800
► PRESS 30 N - 45 N - 60 N - 100 N	Kit electronic	3010173

### PC Interface kit



To connect the control box to a personal computer for the transmission of operation, fault signals and detailed service information, an interface adapter with PC software are available.

BURNER	KIT CODE
► PRESS 30 N - 45 N - 60 N - 100 N	3002719

### Protection kit (electromagnetic interferences)

When the burner is installed in a room particularly subject to electromagnetic interference (signals emitted over 10 V/m) due for example to INVERTER presence or in systems where the lengths of the thermostat connections is over 20 meters, this specific protection kit is available as an interface between the thermostatic controls and the burner.

BURNER	KIT CODE
► All models	3010386

# Two Stage Heavy Oil Burners

## PRESS N SERIES

### Burner accessories

#### Nozzle



#### TYPE F80 PL 45°

The nozzles must be ordered separately. The following table shows the features and codes on the basis of the maximum required output.

NOTE: each burner needs N° 2 nozzles.

BURNER	RATED DELIVERY (kg/h) at 20 bar	GPH	NOZZLE CODE
▶ PRESS 30 N - 45 N	10,6	2	3043121
▶ PRESS 30 N - 45 N	11,9	2,25	3043131
▶ PRESS 30 N - 45 N - 60 N	13,2	2,5	3043141
▶ PRESS 45 N - 60 N	15,8	3	3043151
▶ PRESS 45 N - 60 N - 100 N	18,5	3,5	3043161
▶ PRESS 45 N - 60 N - 100 N	21,1	4	3043171
▶ PRESS 60 N - 100 N	23,7	4,5	3043181
▶ PRESS 60 N - 100 N	26,4	5	3043191
▶ PRESS 100 N	29	5,5	3043201
▶ PRESS 100 N	31,7	6	3043211
▶ PRESS 100 N	34,3	6,5	3043221
▶ PRESS 100 N	36,9	7	3043231
▶ PRESS 100 N	39,6	7,5	3043241
▶ PRESS 100 N	44,8	8,5	3043261

#### TYPE F80 PL 60°

BURNER	RATED DELIVERY (kg/h) at 20 bar	GPH	NOZZLE CODE
▶ PRESS 30 N	6,6	1,25	3041092
▶ PRESS 30 N - 45 N	7,9	1,5	3041102
▶ PRESS 30 N - 45 N	9,2	1,75	3041112
▶ PRESS 30 N - 45 N	10,6	2	3043122
▶ PRESS 30 N - 45 N	11,9	2,25	3043132
▶ PRESS 30 N - 45 N - 60 N	13,2	2,5	3043142
▶ PRESS 45 N - 60 N	15,8	3	3043152
▶ PRESS 45 N - 60 N - 100 N	18,5	3,5	3043162
▶ PRESS 45 N - 60 N - 100 N	21,1	4	3043172
▶ PRESS 60 N - 100 N	23,7	4,5	3043182
▶ PRESS 60 N - 100 N	26,4	5	3043192
▶ PRESS 100 N	29	5,5	3043202
▶ PRESS 100 N	31,7	6	3043212
▶ PRESS 100 N	34,3	6,5	3043222
▶ PRESS 100 N	36,9	7	3043232
▶ PRESS 100 N	39,6	7,5	3043242
▶ PRESS 100 N	44,8	8,5	3043262

## PRESS N/ECO SERIES

PRESS N/ECO burner series covers a firing range from 171 to 1140 kW and it has been designed for operation with low sulphur fuels. The burners are equipped with a separate low speed pump.

They have been designed for use in civil installations of average dimensions, like building areas and large apartment groups or for use in industrial applications, like small or medium plants.

Operation is two stage; a servomotor adjust automatically air damper opening, to obtain the right air delivery on both stage.

The burners are fitted with a microprocessor control panel which supplies indication of operation and diagnosis of fault cause.

The combustion head, that can be set on the basis of required output, allows optimal performance ensuring good combustion and reducing fuel consumption and is available in two different length to be selected on the basis of specific application requirements.

As standard the burners are supplied with electrical heaters installed on crucial parts of hydraulics circuit, for use with heavy oil viscosity up to 20°E.

Simplified maintenance is achieved by the slide bar system, which allows easy access to all of the essential components of the combustion head.



HEAVY OIL

<b>PRESS 30 N/ECO</b>	85/171 ÷ 342 kW
<b>PRESS 45 N/ECO</b>	114/205 ÷ 513 kW
<b>PRESS 60 N/ECO</b>	171/342 ÷ 684 kW
<b>PRESS 100 N/ECO</b>	285/490 ÷ 1140 kW

## FIRING RATES

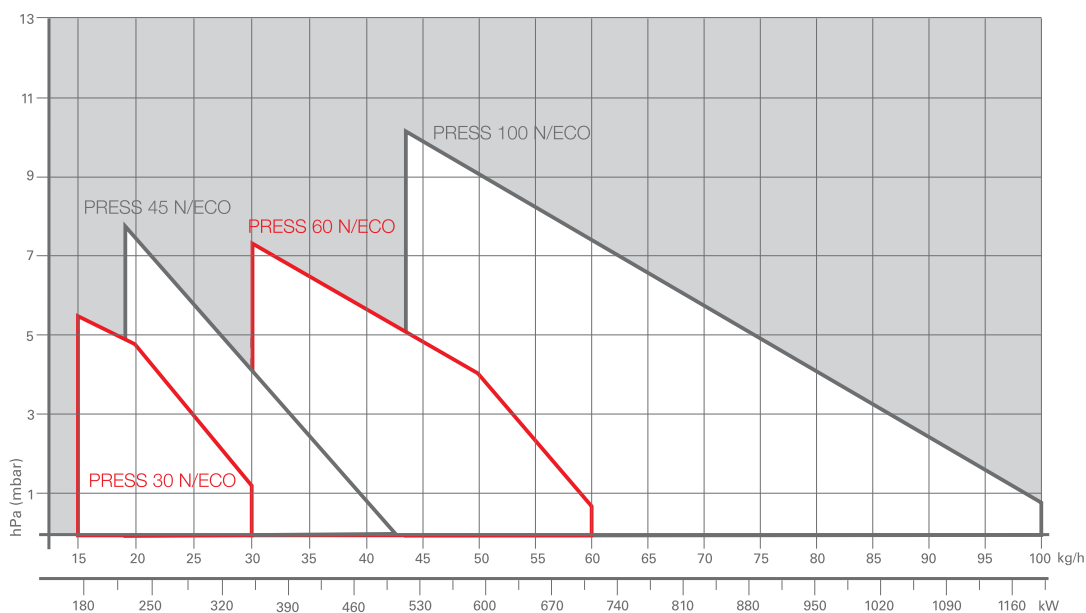

Useful working field for choosing the burner

Test conditions conforming to EN267  
 Temperature: 20°C  
 Pressure: 1013,5 mbar  
 Altitude: 0 m a.s.l.

# Two Stage Heavy Oil Burners

## PRESS N/ECO SERIES

### Overall dimensions (mm)

#### BURNER

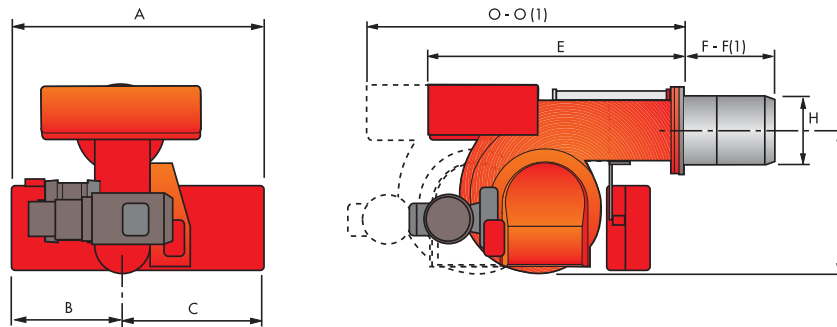

MODEL	A	B	C	E	F - F(1)	H	I	O - O(1)
▶ PRESS 30 N/ECO	625	335	290	625	185 - 320	161	305	968 - 1103
▶ PRESS 45 N/ECO	625	335	290	625	235 - 370	161	305	1018 - 1153
▶ PRESS 60 N/ECO	625	335	290	660	245 - 400	172	335	1079 - 1234
▶ PRESS 100 N/ECO	625	335	290	710	250 - 410	195	370	1126 - 1216

(1) Length with extended combustion head

#### BURNER - BOILER MOUNTING FLANGE

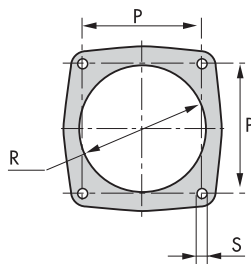

MODEL	P	R	S
▶ PRESS 30 N/ECO	160	170	M 10
▶ PRESS 45 N/ECO	160	170	M 10
▶ PRESS 60 N/ECO	160	180	M 10
▶ PRESS 100 N/ECO	195	205	M 12

#### PACKAGING

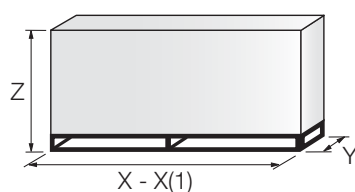

MODEL	X - X(1)	Y	Z	kg
▶ PRESS 30 N/ECO	880 - 1015	690	622	84
▶ PRESS 45 N/ECO	880 - 1015	690	622	84
▶ PRESS 60 N/ECO	925 - 1095	760	652	87
▶ PRESS 100 N/ECO	985 - 1145	790	652	104

(1) Length with extended combustion head

# Two Stage Heavy Oil Burners

## PRESS N/ECO SERIES

**RIELLO**

# Specification

## DESIGNATION OF SERIES

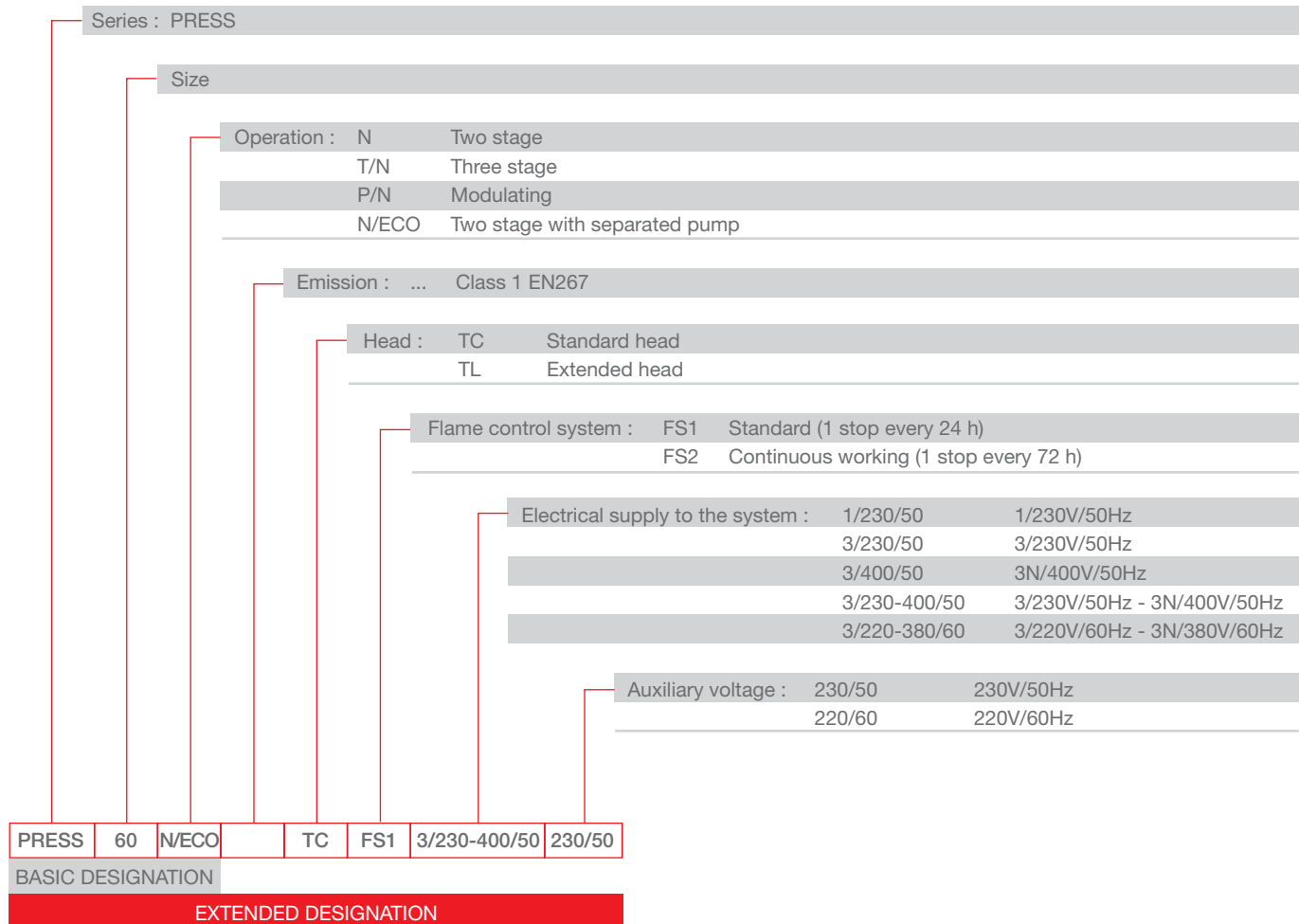

HEAVY OIL

# Two Stage Heavy Oil Burners

## PRESS N/ECO SERIES

### Specification

#### STATE OF SUPPLY

Monoblock forced draught heavy oil burner, two stage operation, made up of:

- Air suction circuit
- Fan with forward curved blades
- Air dampers for air setting controlled by a servomotor
- Fan motor at 2850 rpm
- Oil pump motor at 1400 rpm
- Combustion head, fitted with:
  - stainless steel end cone, resistant to corrosion and high temperatures
  - ignition electrodes
  - flame stability disk
- Gears pump for high pressure fuel supply, fitted with:
  - filter
  - pressure regulator
  - connections for installing a pressure gauge and vacuumeter
  - internal by-pass for single pipe installation
- Valve unit with a double oil safety valve on the output circuit
- Double filter between pump and nozzle
- Oil preheater provided with chance of a thermometer application for temperature control
- Installed electrical heaters on pump, nozzle holder, valves assembly
- Servomotor for air damper regulation
- Air pressure switch
- Photocell for flame detection
- Microprocessor-based burner safety control box, with diagnostic function
- Flame inspection window
- Slide bars for easier installation and maintenance
- Protection filter against radio interference
- IP X0D (IP 40) protection level.

#### Standard equipment:

- 2 flexible hoses for pipe connection
- 2 gaskets for flexible hoses
- 2 nipples for flexible hoses
- 1 thermal insulation screen
- 4 screws for fixing the burner flange to the boiler
- 2 nozzles (see table of available burner model)
- 2 extensions for bars (for long head version)
- Instruction handbook for installation, use and maintenance
- Spare parts catalogue.



# Two Stage Heavy Oil Burners

## PRESS N/ECO SERIES

**RIELLO**

### Available models

CODE	MODEL					HEAT OUTPUT		TOTAL ELECTRICAL POWER (kW)	CERTIFICATION	NOTE
						(kW)	(kg/h)			
3433823	PRESS 30 N/ECO	TC	FS1	3/230-400/50	230/50	85/171-342	7,5/15-30	3,9	-	(1) (2)
3433824	PRESS 30 N/ECO	TL	FS1	3/230-400/50	230/50	85/171-342	7,5/15-30	3,9	-	(1) (2)
3433881	PRESS 30 N/ECO	TC	FS1	3/220-380/60	220/60	85/171-342	7,5/15-30	4,2	-	(2)
3433882	PRESS 30 N/ECO	TL	FS1	3/220-380/60	220/60	85/171-342	7,5/15-30	4,2	-	(2)
3434623	PRESS 45 N/ECO	TC	FS1	3/230-400/50	230/50	114/205-513	10/18-45	4,1	-	(1) (2)
3434624	PRESS 45 N/ECO	TL	FS1	3/230-400/50	230/50	114/205-513	10/18-45	4,1	-	(1) (2)
3434681	PRESS 45 N/ECO	TC	FS1	3/220-380/60	220/60	114/205-513	10/18-45	4,2	-	(2)
3434682	PRESS 45 N/ECO	TL	FS1	3/220-380/60	220/60	114/205-513	10/18-45	4,2	-	(2)
3435023	PRESS 60 N/ECO	TC	FS1	3/230-400/50	230/50	171/342-684	15/30-60	6,0	-	(1) (2)
3435024	PRESS 60 N/ECO	TL	FS1	3/230-400/50	230/50	171/342-684	15/30-60	6,0	-	(1) (2)
3435081	PRESS 60 N/ECO	TC	FS1	3/220-380/60	220/60	171/342-684	15/30-60	6,3	-	(2)
3435082	PRESS 60 N/ECO	TL	FS1	3/220-380/60	220/60	171/342-684	15/30-60	6,3	-	(2)
3436023	PRESS 100 N/ECO	TC	FS1	3/230-400/50	230/50	285/490-1140	25/43-100	9,5	-	(1) (2)
3436024	PRESS 100 N/ECO	TL	FS1	3/230-400/50	230/50	285/490-1140	25/43-100	9,5	-	(1) (2)
3436081	PRESS 100 N/ECO	TC	FS1	3/220-380/60	220/60	285/490-1140	25/43-100	9,5	-	(2)
3436082	PRESS 100 N/ECO	TL	FS1	3/220-380/60	220/60	285/490-1140	25/43-100	9,5	-	(2)

(1) 2 nozzles as standard equipment.

(2) Installed electrical heaters on pump, nozzle holder, valves assembly

Net calorific value: 11,16 kWh/kg; 9600 kcal/kg - Max Viscosity at 50°C: 20°E (150 mm<sup>2</sup>/s, cSt), Type BUNKER B / USA n° 5.

The burners of PRESS series are in according to 89/336 (2004/108) - 73/23 (2006/95) EC Directive and EN 267 Norm.

# Two Stage Heavy Oil Burners

## PRESS N/ECO SERIES

### Burner accessories

#### Extended head kit

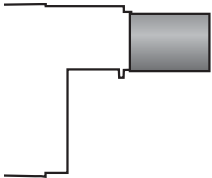

“Standard head” burners can be transformed into “extended head” versions, by using the special kit. The KITS available for the various burners, giving the original and the extended lengths, are listed below.

BURNER	STANDARD HEAD LENGTH (mm)	EXTENDED HEAD LENGTH (mm)	KIT CODE
► PRESS 30 N/ECO	185	320	20015280
► PRESS 60 N/ECO	245	400	3092198

#### Spacer kit



If burner head penetration into the combustion chamber needs reducing, varying thickness spacers are available, as given in the list.

BURNER	SPACER THICKNESS S (mm)	KIT CODE
► P 30 N/ECO - 45 N/ECO - 60 N/ECO	142	3000755
► P 100 N/ECO	142	3000802

#### Sound proofing box

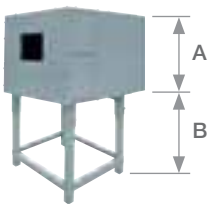

If noise emission needs reducing even further, sound-proofing boxes are available.

BURNER	BOX TYPE	A (mm)	B (mm) min-max	[dB(A)] (*)	BOX CODE
► PRESS 30 - 45 - 60 - 100 N/ECO	C4/5	850	160 - 980	10	3010404

(\*) Average noise reduction according to EN 15036-1 standard

#### Self-cleaning filter



For cleaning heavy oil from dirty particles and impurities, it is equipped with a thermostatic heater for oil with 50°E viscosity at 50°C.

FILTER TYPE	FILTER CODE
► $\phi=1$ 50°E - 50°C	3000790

HEATER TYPE	HEATER CODE
► Thermostatic heater 80W	3010059

#### Cartridge filter



For cleaning heavy oil from dirty particles and impurities, it is equipped with a cartridge system for oil with 7°E viscosity at 50°C.

FILTER TYPE	FILTER CODE
► Cartridge 7°E - 50°C	3005209

HEATER TYPE	HEATER CODE
► Thermo - resistance up to 30°E - 50°	3010050

## Burner accessories

### Thermostats

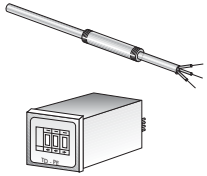

Thermostats allow heavy oil temperature control and regulation during burner operation. They are available in electronic and maximum versions.

BURNER	THERMOSTAT TYPE	THERMOSTAT CODE
▶ P 30 N/ECO - 45 N/ECO - 60 N/ECO - 100 N/ECO	Electronic	3000799

### PC Interface kit



To connect the control box to a personal computer for the transmission of operation, fault signals and detailed service information, an interface adapter with PC software are available.

BURNER	KIT CODE
▶ P 30 N/ECO - 45 N/ECO - 60 N/ECO - 100 N/ECO	3002719

### Protection kit (electromagnetic interferences)

When the burner is installed in a room particularly subject to electromagnetic interference (signals emitted over 10 V/m) due for example to INVERTER presence or in systems where the lengths of the thermostat connections is over 20 meters, this specific protection kit is available as an interface between the thermostatic controls and the burner.

BURNER	KIT CODE
All models	3010386

# Two Stage Heavy Oil Burners

## PRESS N/ECO SERIES

### Burner accessories

#### Nozzle



#### TYPE F80 PL 45°

The nozzles must be ordered separately. The following table shows the features and codes on the basis of the maximum required output.

NOTE: each burner needs N° 2 nozzles.

BURNER	RATED DELIVERY (kg/h) at 20 bar	GPH	NOZZLE CODE
▶ P 30 N/ECO - 45 N/ECO	10,6	2	3043121
▶ P 30 N/ECO - 45 N/ECO	11,9	2,25	3043131
▶ P 30 N/ECO - 45 N/ECO - 60 N/ECO	13,2	2,5	3043141
▶ P 45 N/ECO - 60 N/ECO	15,8	3	3043151
▶ P 45 N/ECO - 60 N/ECO - 100 N/ECO	18,5	3,5	3043161
▶ P 45 N/ECO - 60 N/ECO - 100 N/ECO	21,1	4	3043171
▶ P 60 N/ECO - 100 N/ECO	23,7	4,5	3043181
▶ P 60 N/ECO - 100 N/ECO	26,4	5	3043191
▶ P 100 N/ECO	29	5,5	3043201
▶ P 100 N/ECO	31,7	6	3043211
▶ P 100 N/ECO	34,3	6,5	3043221
▶ P 100 N/ECO	36,9	7	3043231
▶ P 100 N/ECO	39,6	7,5	3043241
▶ P 100 N/ECO	44,8	8,5	3043261

#### TYPE F80 PL 60°

BURNER	RATED DELIVERY (kg/h) at 20 bar	GPH	NOZZLE CODE
▶ P 30 N/ECO	6,6	1,25	3041092
▶ P 30 N/ECO - 45 N/ECO	7,9	1,5	3041102
▶ P 30 N/ECO - 45 N/ECO	9,2	1,75	3041112
▶ P 30 N/ECO - 45 N/ECO	10,6	2	3043122
▶ P 30 N/ECO - 45 N/ECO	11,9	2,25	3043132
▶ P 30 N/ECO - 45 N/ECO - 60 N/ECO	13,2	2,5	3043142
▶ P 45 N/ECO - 60 N/ECO	15,8	3	3043152
▶ P 45 N/ECO - 60 N/ECO - 100 N/ECO	18,5	3,5	3043162
▶ P 45 N/ECO - 60 N/ECO - 100 N/ECO	21,1	4	3043172
▶ P 60 N/ECO - 100 N/ECO	23,7	4,5	3043182
▶ P 60 N/ECO - 100 N/ECO	26,4	5	3043192
▶ P 100 N/ECO	29	5,5	3043202
▶ P 100 N/ECO	31,7	6	3043212
▶ P 100 N/ECO	34,3	6,5	3043222
▶ P 100 N/ECO	36,9	7	3043232
▶ P 100 N/ECO	39,6	7,5	3043242
▶ P 100 N/ECO	44,8	8,5	3043262

## PRESS T/N - T/N ECO SERIES

The PRESS T/N series of burners covers a firing range from 800 to 5130 kW. They have been designed in three versions for use in commercial and industrial installations, to burn different oil viscosity from 7 up to 60 °E @ 50°C. Operation is three-stage, thus making these burners suitable for installations that have variable but predictable heating requirements.

A servomotor adjusts automatically air damper to the opening value, determined to obtain always the necessary fuel consumption. Every model of PRESS T/N series is available in two different combustion head length (short or long head) to be selected on the basis of specific application requirements. An electric preheater has been fitted to maintain the oil at the correct atomising temperature at maximum output and special heaters kits are separately supplied for burning high viscosity oil.

Simplified maintenance is achieved by the Riello designed slide bar system, which allows easy access to all of the essential components of the combustion head.



HEAVY OIL

P 140 T/N	320/800 ÷ 1600 kW
P 200 T/N	515/1140 ÷ 2280 kW
P 300 T/N	626/1710 ÷ 3420 kW
P 450 T/N	855/2560 ÷ 5130 kW
P 140 T/N ECO	320/800 ÷ 1600 kW
P 200 T/N ECO	515/1140 ÷ 2280 kW
P 300 T/N ECO	626/1710 ÷ 3420 kW
P 450 T/N ECO	855/2560 ÷ 5130 kW

### FIRING RATES

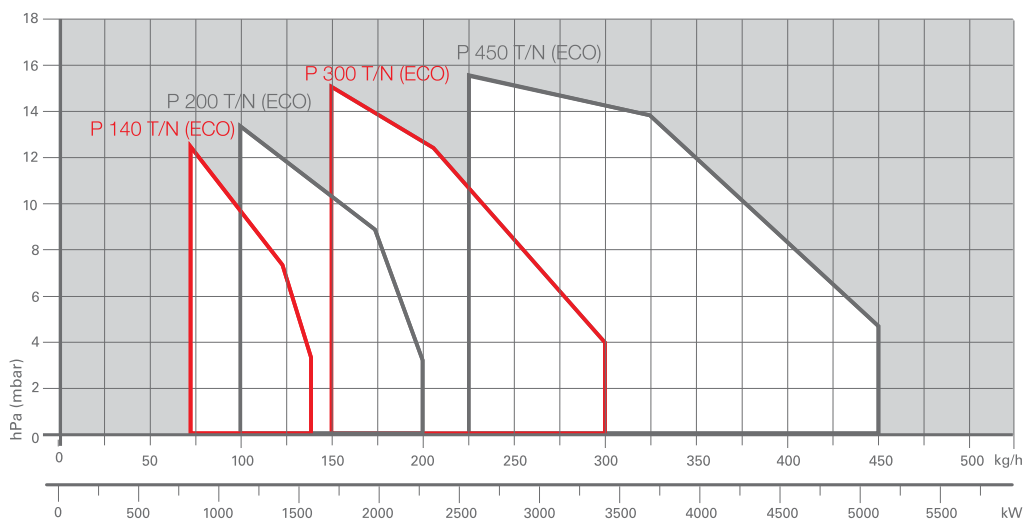

Useful working field for choosing the burner

Test conditions conforming to EN267  
 Temperature: 20°C  
 Pressure: 1013,5 mbar  
 Altitude: 0 m a.s.l.

# Three Stage Heavy Oil Burners

## PRESS T/N - T/N ECO SERIES

### Overall dimensions (mm)

#### BURNER

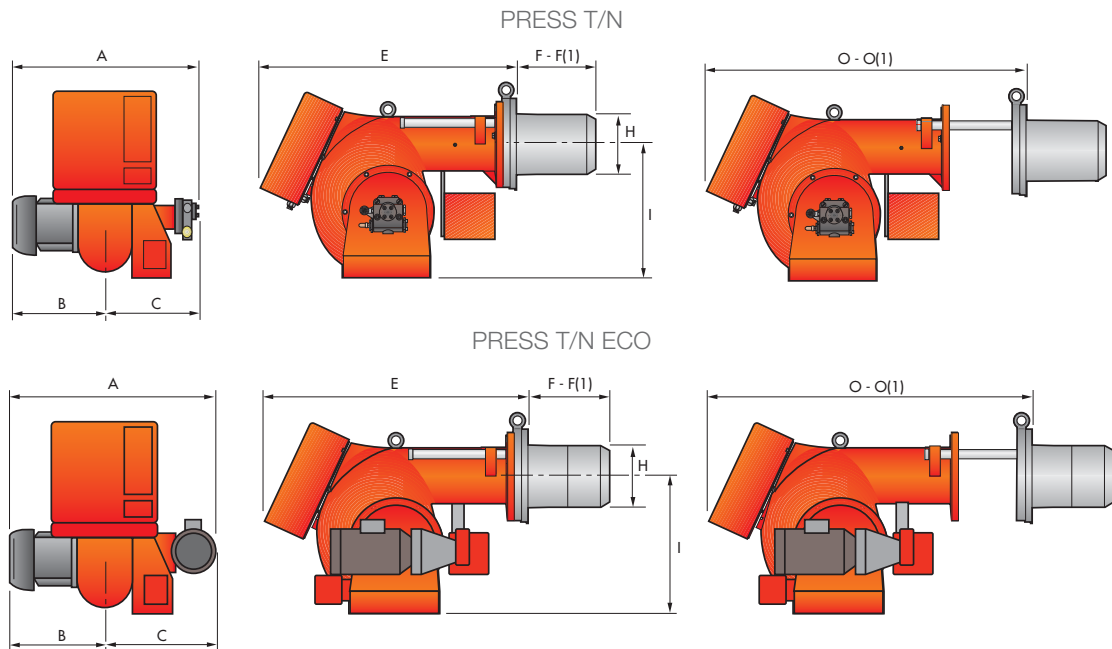

MODEL	A	B	C	E	F - F(1)	H	I	O - O(1)
▶ P 140 T/N	796	396	400	890	323 - 433	222	467	1370 - 1370
▶ P 200 T/N	796	396	400	890	352 - 462	250	467	1370 - 1370
▶ P 300 T/N	858	447	411	1000	376 - 506	295	496	1515 - 1665
▶ P 450 T/N	950	508	442	1090	435 - 565	336	525	1665 - 1820
▶ P 140 T/N ECO	900	396	504	890	323 - 433	222	467	1370 - 1370
▶ P 200 T/N ECO	900	396	504	890	352 - 462	250	467	1370 - 1370
▶ P 300 T/N ECO	984	447	537	1000	376 - 506	295	496	1515 - 1665
▶ P 450 T/N ECO	1100	508	592	1090	435 - 565	336	525	1665 - 1820

(1) Length with extended combustion head

#### BURNER - BOILER MOUNTING FLANGE

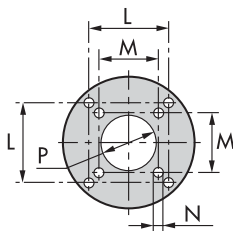

MODEL	L	M	N	P
▶ P 140 T/N (ECO)	260	230	M 14	225
▶ P 200 T/N (ECO)	260	-	M 16	255
▶ P 300 T/N (ECO)	260	-	M 18	300
▶ P 450 T/N (ECO)	310	-	M 20	350

#### PACKAGING

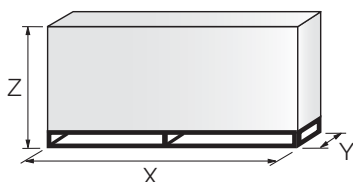

MODEL	X	Y	Z	kg
▶ P 140 T/N (ECO)	1500	930	900	180
▶ P 200 T/N (ECO)	1500	930	900	190
▶ P 300 T/N (ECO)	1780	1085	990	260
▶ P 450 T/N (ECO)	1780	1085	990	350

# Three Stage Heavy Oil Burners

## PRESS T/N - T/N ECO SERIES

**RIELLO**

# Specification

## DESIGNATION OF SERIES

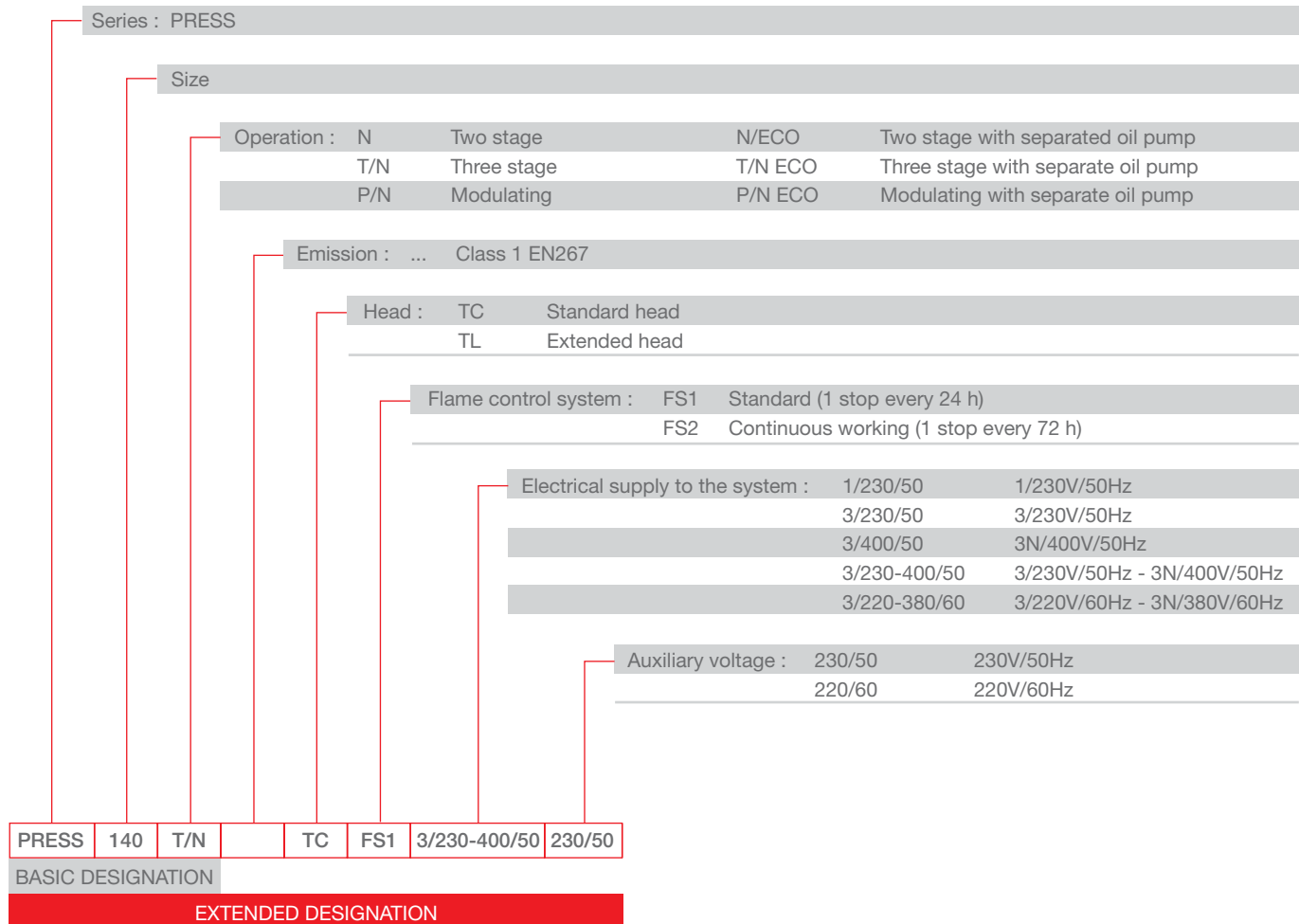

HEAVY OIL

# Three Stage Heavy Oil Burners

## PRESS T/N - T/N ECO SERIES

### Specification

#### STATE OF SUPPLY

Monoblock forced draught heavy oil burner, three stage operation, made up of:

- Air suction circuit
- Fan with forward curved blades
- Air dampers for air setting controlled by a servomotor
- Fan motor at 2850 rpm
- Combustion head, fitted with:
  - stainless steel end cone, resistant to corrosion and high temperatures
  - ignition electrodes
  - flame stability disk
- Gears pump for high pressure fuel supply, fitted with:
  - filter
  - pressure regulator
  - connections for installing a pressure gauge and vacuumeter
  - internal by-pass for single pipe installation
- Valve unit with a oil safety shut-off valve fitted in series with three valves controlling three-stage on the output circuit
- Heavy oil heating cartridges (T/N ECO version)
- Oil pump motor at 1400 rpm (T/N ECO version)
- Oil preheater
- Servomotor for air damper regulation
- Photocell for flame detection
- Burner safety control box
- Flame inspection window
- Slide bars for easier installation and maintenance
- Protection filter against radio interference
- IP X0D (IP 40) electric protection level.

#### Standard equipment:

- 2 flexible hoses for pipe connection
- 2 nipples for flexible hoses
- 1 thermal insulation screen
- 4 screws for fixing the burner flange to the boiler
- 3 nozzles
- 2 extensions for bars (for long head version of P 300 T/N and P 450 T/N)
- 5 wiring looms for electrical connections (7 for P 450 T/N version)
- 1 star delta starter (only for P 450 T/N version)
- Instruction handbook for installation, use and maintenance
- Spare parts catalogue.



# Three Stage Heavy Oil Burners

## PRESS T/N - T/N ECO SERIES

**RIELLO**

### Available models

CODE	MODEL						HEAT OUTPUT		TOTAL ELECTRICAL POWER (kW)	CERTIFICATION	NOTE
							(kW)	(kg/h)			
3436833	PRESS 140 T/N	TC	FS1	3/230-400/50	230/50	320-1600	28-140	19	-		
3436834	PRESS 140 T/N	TL	FS1	3/230-400/50	230/50	320-1600	28-140	19	-		
3436885	PRESS 140 T/N	TC	FS1	3/220-380/60	220/60	320-1600	28-140	19	-		
3436886	PRESS 140 T/N	TL	FS1	3/220-380/60	220/60	320-1600	28-140	19	-		
3437733	PRESS 200 T/N	TC	FS1	3/230-400/50	230/50	515-2280	45-200	20	-		
3437734	PRESS 200 T/N	TL	FS1	3/230-400/50	230/50	515-2280	45-200	20	-		
3437785	PRESS 200 T/N	TC	FS1	3/220-380/60	220/60	515-2280	45-200	20	-		
3437786	PRESS 200 T/N	TL	FS1	3/220-380/60	220/60	515-2280	45-200	20	-		
3438964	PRESS 300 T/N	TC	FS1	3/230-400/50	230/50	626-3420	60-300	30	-		
3438965	PRESS 300 T/N	TL	FS1	3/230-400/50	230/50	626-3420	60-300	30	-		
3438966	PRESS 300 T/N	TC	FS1	3/230/50	230/50	626-3420	60-300	30	-	(1)	
3438967	PRESS 300 T/N	TL	FS1	3/230/50	230/50	626-3420	60-300	30	-	(1)	
3438968	PRESS 300 T/N	TC	FS1	3/400/50	230/50	626-3420	60-300	30	-	(1)	
3438969	PRESS 300 T/N	TL	FS1	3/400/50	230/50	626-3420	60-300	30	-	(1)	
3439345	PRESS 450 T/N	TC	FS1	3/230/50	230/50	855-5130	75-450	34	-	(2)	
3439346	PRESS 450 T/N	TL	FS1	3/230/50	230/50	855-5130	75-450	34	-	(2)	
3439347	PRESS 450 T/N	TC	FS1	3/400/50	230/50	855-5130	75-450	34	-	(2)	
3439348	PRESS 450 T/N	TL	FS1	3/400/50	230/50	855-5130	75-450	34	-	(2)	

(1) Star-delta starting, on board

(2) Star-delta starting, as standard equipment

Net calorific value: 11,16 kWh/kg; 9600 kcal/kg

Max Viscosity at 50°C for PRESS T/N: 7°E (50 mm<sup>2</sup>/s, cSt), Type MEDIUM HEAVY OIL / USA n° 4.

Max Viscosity at 50°C for PRESS T/N ECO: 20°E (150 mm<sup>2</sup>/s, cSt), Type BUNKER B / USA n° 5.

For higher viscosity please contact Riello Burners Technical Department.

The burners of PRESS series are in according to 89/336 (2004/108) - 73/23 (2006/95) EC Directive and EN 267 Norm.

For ECO models ask for specific code.

#### Special configuration on demand:

- Installed pipes heating cable on PRESS T/N - T/N ECO models, Max Viscosity at 50°C: 60°E (450 mm<sup>2</sup>/s, cSt), Type BUNKER C / USA n° 6.
- Steam oil pre-heater on T/N ECO models.

# Three Stage Heavy Oil Burners

## PRESS T/N - T/N ECO SERIES

### Burner accessories

Available for T/N and T/N ECO versions

#### Nozzle type F80 PL 60°



The nozzles must be ordered separately. The following table shows the features and codes on the basis of the maximum required output.

NOTE: each burner needs N° 3 nozzles.

BURNER	RATED DELIVERY (kg/h) at 25 bar	GPH	NOZZLE CODE
► P 140 T/N	20,8	3,5	3043162
► P 140 T/N	23,8	4	3043172
► P 140 T/N	26,8	4,5	3043182
► P 140 T/N - P 200 T/N	29,8	5	3043192
► P 140 T/N - P 200 T/N	32,7	5,5	3043202
► P 140 T/N - P 200 T/N	35,7	6	3043212
► P 140 T/N - P 200 T/N	38,7	6,5	3043222
► P 140 T/N - P 200 T/N	41,7	7	3043232
► P 140 T/N - P 200 T/N	44,6	7,5	3043242
► P 200 T/N - P 300 T/N	50,6	8,5	3043262
► P 200 T/N - P 300 T/N	56,5	9,5	3043272
► P 200 T/N - P 300 T/N - P 450 T/N	62,5	10,5	3043302
► P 300 T/N - P 450 T/N	71,4	12	3043322
► P 300 T/N - P 450 T/N	80,4	13,5	3043342
► P 300 T/N - P 450 T/N	92,3	15,5	3043372
► P 450 T/N	104,2	17,5	3043402
► P 450 T/N	116,1	19,5	3043432
► P 450 T/N	128	21,5	3043452
► P 450 T/N	142,8	24	3043472

#### Extended head kit

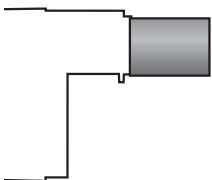

“Standard head” burners can be transformed into “extended head” versions, by using the special kit. The KITS available for the various burners, giving the original and the extended lengths, are listed below.

BURNER	STANDARD HEAD LENGTH (mm)	EXTENDED HEAD LENGTH (mm)	KIT CODE
► PRESS 200 T/N	352	462	20047317

#### Spacer kit



If burner head penetration into the combustion chamber needs reducing, varying thickness spacers are available, as given in the list.

BURNER	SPACER THICKNESS S (mm)	KIT CODE
► P 140 T/N - P 200 T/N	102	3000722
► P 300 T/N	110	3000723
► P 450 T/N	130	3000751

## Burner accessories

### Sound proofing box

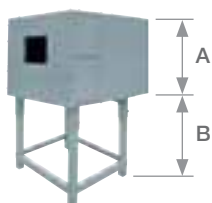

If noise emission needs reducing even further, sound-proofing boxes are available.

BURNER	BOX TYPE	A (mm)	B (mm) min-max	[dB(A)] (*)	BOX CODE
▶ P 140 T/N - P 200 T/N	C4/5	850	160 - 980	10	3010404
▶ P 300 T/N - P 450 T/N	C7	1255	160 - 980	10	3010376
▶ P 140 - 200 - 300 - 450 T/N ECO	C7	1255	160 - 980	10	3010376

(\*) Average noise reduction according to EN 15036-1 standard

### Self-cleaning filter



For cleaning heavy oil from dirty particles and impurities, it is equipped with a thermostatic heater for oil with 60°E viscosity at 50°C.

FILTER TYPE	FILTERING DEGREE (µm)	FILTER CODE
▶ Ø = 1"1/2 (60°E at 50°C)	300	3010022

HEATER / THERMOSTAT TYPE	HEATER / THERMOSTAT CODE
▶ Thermostatic heater with LED	3010060
▶ Heater	3010061
▶ Thermostat (two-stage / regulable)	3010062

### Gas separator bottle



Gas separator bottle connects the burner oil circuit to the main ring circuit. It allows to recover heat in excess and discharge return circuit gas.

BURNER	CODE
▶ P 140 T/N - P 200 T/N	3000748
▶ P 300 T/N - P 450 T/N	3010012

### Heavy oil kit

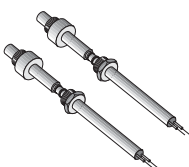

Equipped with electrical heaters, it permits the employment of PRESS T/N burners with fuel oil of max. viscosity at 50°C: 20°E (150 mm<sup>2</sup>/s, cSt), Type BUNKER B / USA n° 5.

BURNER	KIT CODE
▶ P 140 T/N - P 200 T/N - P 300 T/N - P 450 T/N	3000721

# Three Stage Heavy Oil Burners

## PRESS T/N - T/N ECO SERIES

### Burner accessories

#### Heavy oil precirculation kit



This kit, used with oil with high viscosity, in maintains fuel circulation in the oil circuit for avoiding system stop at start up.

BURNER	KIT CODE
► P 140 T/N - P 200 T/N	3000749
► P 300 T/N - P 450 T/N	3000750

#### Burner support

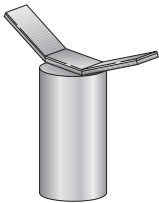

For easier maintenance, a mobile burner support has been designed, which means the burner can be dismantled without the need of forklift trucks.

BURNER	SUPPORT CODE
► P 300 T/N - P 450 T/N	3000731

#### PC Interface kit



To connect the control box to a personal computer for the transmission of operation, fault signals and detailed service information, an interface adapter with PC software are available.

BURNER	KIT CODE
► P 140 T/N - P 200 T/N - P 300 T/N - P 450 T/N	3002719

#### Protection kit (electromagnetic interferences)

When the burner is installed in a room particularly subject to electromagnetic interference (signals emitted over 10 V/m) due for example to INVERTER presence or in systems where the lengths of the thermostat connections is over 20 meters, this specific protection kit is available as an interface between the thermostatic controls and the burner.

BURNER	KIT CODE
► All models	3010386

## PRESS P/N - P/N ECO SERIES

The PRESS P/N series of burners covers a firing range from 800 to 5130 kW. They have been designed in three versions for use in commercial and industrial installation, to burn different oil viscosity from 7 up to 60°E @ 50°C.

Operation can be “two stage progressive” or, alternatively, “modulating” with the installation of a PID logic regulator and respective probes, which guarantees a turn down ratio of 3:1.

The versatility of this range makes the burner well suited for use on steam boilers where the load factor is subject to wide variations, on thermal oil boilers and on boilers for particular heating plants, as hospitals or similar.

Simplified maintenance is achieved by the Riello designed slide bar system, which allows easy access to all of the essential components of the combustion head.



P 140 P/N	400/800 ÷ 1600	kW
P 200 P/N	570/1140 ÷ 2280	kW
P 300 P/N	683/1710 ÷ 3420	kW
P 450 P/N	1140/2615 ÷ 5130	kW
P 140 P/N ECO	400/800 ÷ 1600	kW
P 200 P/N ECO	570/1140 ÷ 2280	kW
P 300 P/N ECO	683/1710 ÷ 3420	kW
P 450 P/N ECO	1140/2615 ÷ 5130	kW

### FIRING RATES

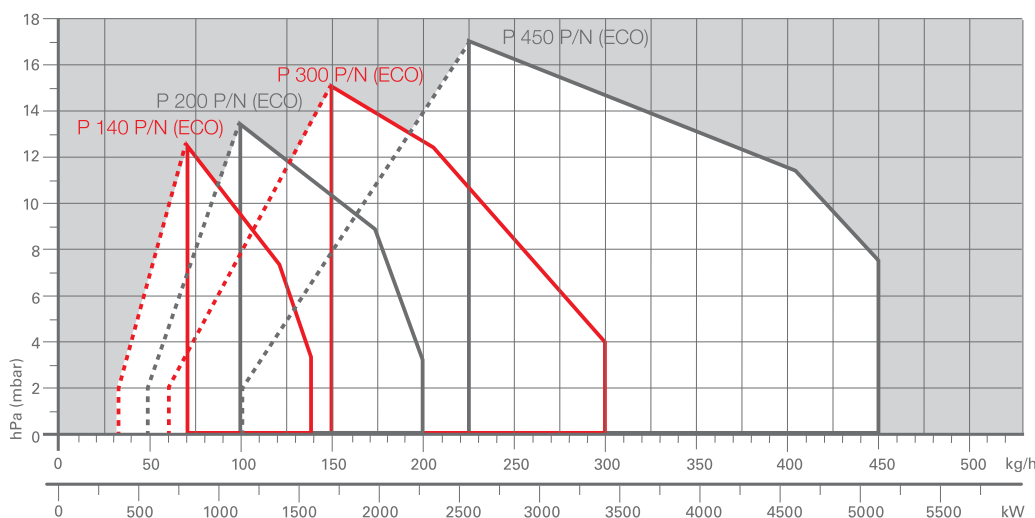

 Useful working field for choosing the burner

 Modulation range

Test conditions conforming to EN267  
Temperature: 20°C  
Pressure: 1013,5 mbar  
Altitude: 0 m a.s.l.

# Modulating Heavy Oil Burners

## PRESS P/N - P/N ECO SERIES

### Overall dimensions (mm)

#### BURNER

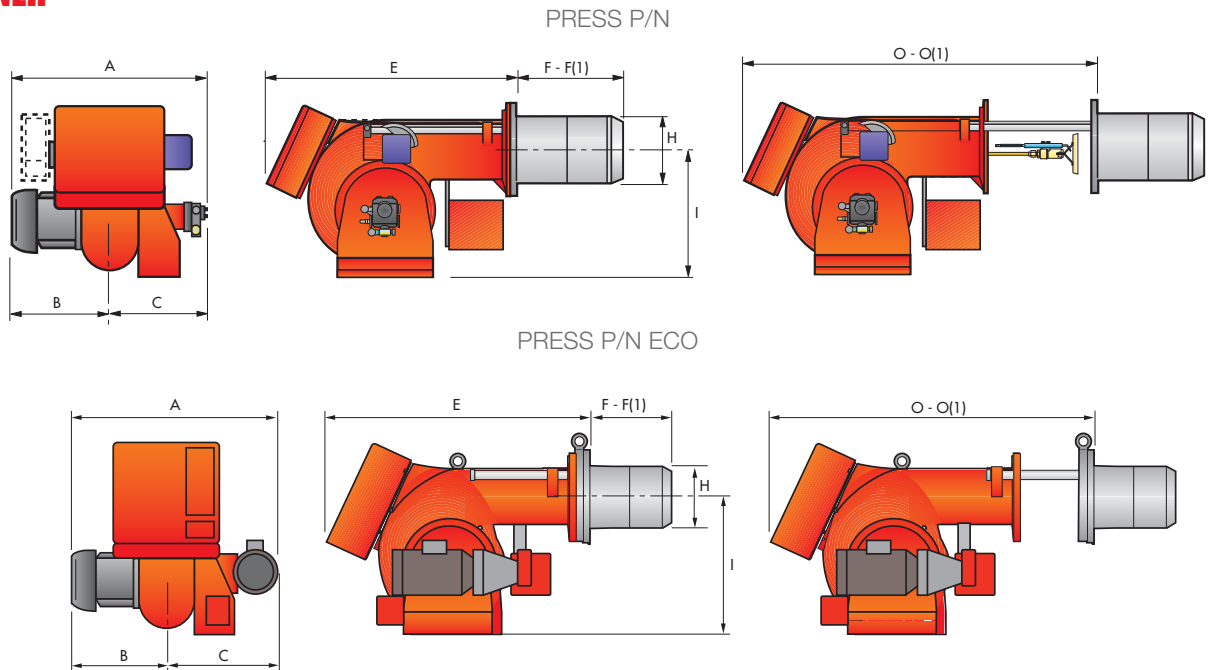

MODEL	A	B	C	E	F - F(1)	H	I	O - O(1)
▶ P 140 P/N	796	396	400	910	323 - 433	222	467	1390 - 1390
▶ P 200 P/N	796	396	400	910	352 - 462	250	467	1390 - 1390
▶ P 300 P/N	858	447	411	1020	376 - 506	295	496	1535 - 1685
▶ P 450 P/N	950	508	442	1090	435 - 565	336	525	1665 - 1820
▶ P 140 P/N ECO	900	396	504	890	323 - 433	222	467	1370 - 1370
▶ P 200 P/N ECO	900	396	504	890	352 - 462	250	467	1370 - 1370
▶ P 300 P/N ECO	984	447	537	1000	376 - 506	295	496	1515 - 1665
▶ P 450 P/N ECO	1100	508	592	1090	435 - 565	336	525	1665 - 1820

(1) Length with extended combustion head

#### BURNER - BOILER MOUNTING FLANGE

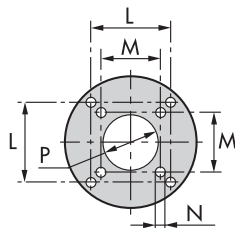

MODEL	L	M	N	P
▶ P 140 P/N (ECO)	260	230	M 14	225
▶ P 200 P/N (ECO)	260	-	M 16	255
▶ P 300 P/N (ECO)	260	-	M 18	300
▶ P 450 P/N (ECO)	310	-	M 20	350

#### PACKAGING

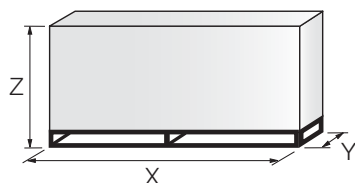

MODEL	X	Y	Z	kg
▶ P 140 P/N (ECO)	1500	930	900	180
▶ P 200 P/N (ECO)	1500	930	900	220
▶ P 300 P/N (ECO)	1780	1085	990	238
▶ P 450 P/N (ECO)	1780	1085	990	300

# Modulating Heavy Oil Burners

## PRESS P/N - P/N ECO SERIES

**RIELLO**

# Specification

## DESIGNATION OF SERIES

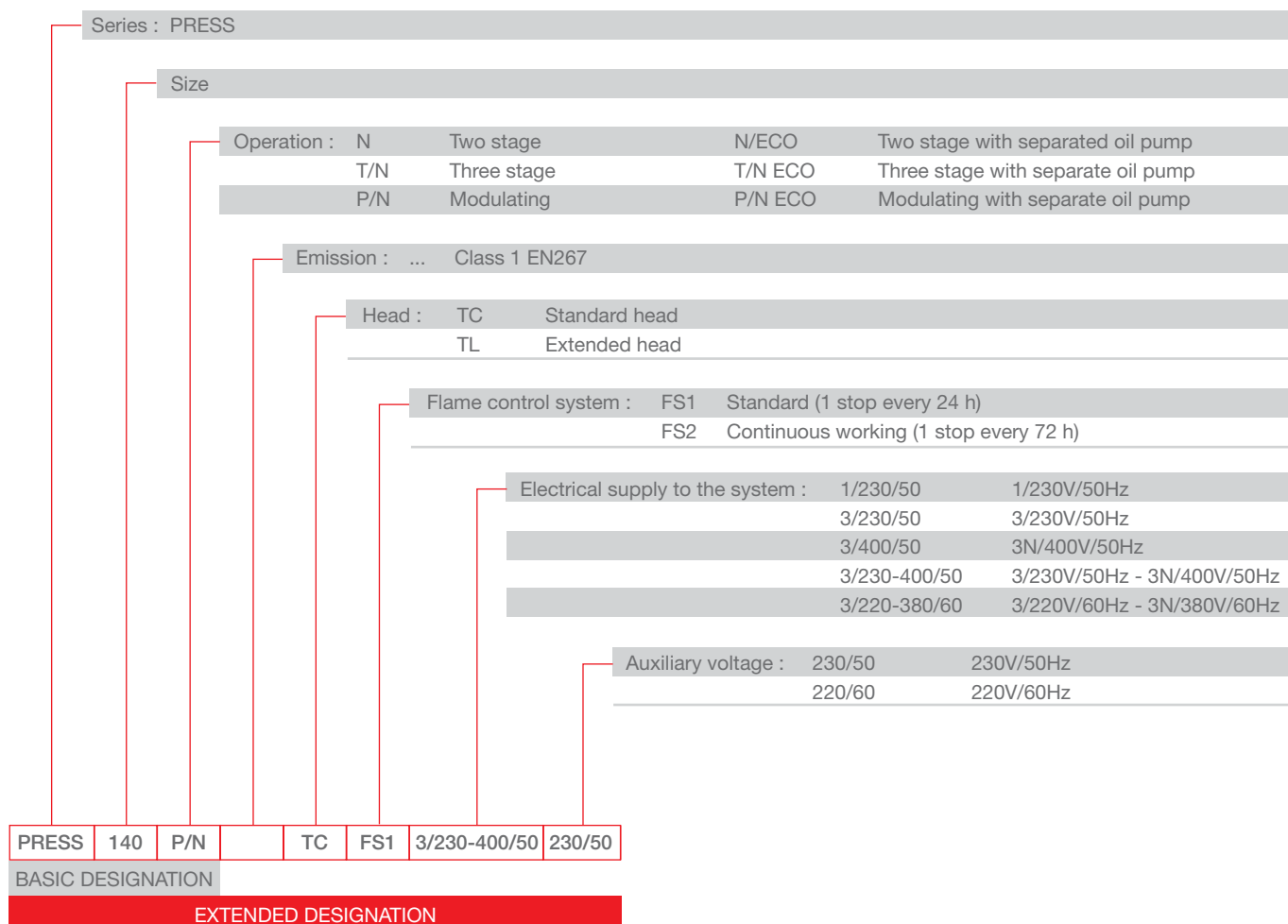

HEAVY OIL

# Modulating Heavy Oil Burners

## PRESS P/N - P/N ECO SERIES

### Specification

#### STATE OF SUPPLY

Monoblock forced draught oil burner with two-stage progressive or modulating operation, with a specific kit, fully automatic, made up of:

- Air suction circuit lined with sound-proofing material
- Fan with forward curved blades high performance pressure levels
- Air damper for air setting and automatic oil output regulator controlled by a servomotor with variable cam
- Fan motor at 2850 rpm, three-phase 400V with neutral, 50Hz
- Combustion head, that can be set on the basis of the combustion output, fitted with:
  - stainless steel end cone, resistant to corrosion and high temperatures
  - ignition electrodes
  - flame stability disk
- Gears pump for high pressure fuel supply, fitted with:
  - filter
  - pressure regulator
  - connections for installing a pressure gauge and vacuumeter
  - internal by-pass for single pipe installation
- Heavy oil heating cartridges (P/N ECO version)
- Pipes heating cable (P/N ECO version)
- Oil pump motor at 1400 rpm (P/N ECO version)
- Valve unit with a double oil safety valve on the output circuit
- Electrical preheater for heavy oil
- Safety oil pressure switch
- Photocell for flame detection
- Burner safety control box, fitted with control function for the correct positioning of the servomotor and possibility of post-ventilation by just changing the electric wiring
- Flame inspection window
- Slide bars for easier installation and maintenance
- Protection filter against radio interference
- IP X0D (IP 40) electric protection level.

#### Standard equipment:

- 2 flexible pipes for connection to the oil supply network
- 2 nipples for the connection to the pump
- Wiring looms fittings for electrical connections
- 4 screws for fixing the burner flange to the boiler
- 2 slide bar extensions (for the extended head models of P 300 P/N and P 450 P/N)
- Gasket for flange
- Starter\*
- Instruction handbook for installation, use and maintenance
- Spare parts catalogue.

\* for versions with star-delta starting



# Modulating Heavy Oil Burners

## PRESS P/N - P/N ECO SERIES

**RIELLO**

## Available models

CODE	MODEL						HEAT OUTPUT		TOTAL ELECTRICAL POWER (kW)	CERTIFICATION	NOTE
							(kW)	(kg/h)			
3436876	P 140 P/N	TC	FS1	3/230-400/50	230/50	400/800÷1600	35/70÷140	19	-		
3436877	P 140 P/N	TL	FS1	3/230-400/50	230/50	400/800÷1600	35/70÷140	19	-		
3437776	P 200 P/N	TC	FS1	3/230-400/50	230/50	570/1140÷2280	50/100÷200	20	-		
3437777	P 200 P/N	TL	FS1	3/230-400/50	230/50	570/1140÷2280	50/100÷200	20	-		
3438989	P 300 P/N	TC	FS1	3/230/50	230/50	683/1710÷3420	60/150÷300	30	-	(1)	
3438987	P 300 P/N	TC	FS1	3/230-400/50	230/50	683/1710÷3420	60/150÷300	30	-		
3438991	P 300 P/N	TC	FS1	3/400/50	230/50	683/1710÷3420	60/150÷300	30	-	(1)	
3438990	P 300 P/N	TL	FS1	3/230/50	230/50	683/1710÷3420	60/150÷300	30	-	(1)	
3438988	P 300 P/N	TL	FS1	3/230-400/50	230/50	683/1710÷3420	60/150÷300	30	-		
3438992	P 300 P/N	TL	FS1	3/400/50	230/50	683/1710÷3420	60/150÷300	30	-	(1)	
3439385	P 450 P/N	TC	FS1	3/230/50	230/50	1140/2615÷5130	100/225÷450	34	-	(1)	
3439387	P 450 P/N	TC	FS1	3/400/50	230/50	1140/2615÷5130	100/225÷450	34	-	(1)	
3439386	P 450 P/N	TL	FS1	3/230/50	230/50	1140/2615÷5130	100/225÷450	34	-	(1)	
3439388	P 450 P/N	TL	FS1	3/400/50	230/50	1140/2615÷5130	100/225÷450	34	-	(1)	

Net calorific value: 11,16 kWh/kg; 9600 kcal/kg

The burners of PRESS series are in according to 89/336 (2004/108) - 73/23 (2006/95) EC Directive and EN 267 Norm.

(1) Star-delta starting

### Viscosity

The modulating burner P/N series can burn different heavy oil types from 7 up to 60°E @ 50°C (50 up to 450 cSt @ 50°C).

For different viscosity levels Riello recommends 3 different configurations:

- 1) PRESS P/N version for viscosity up to 7°E (50 mm<sup>2</sup>/s, cSt), Type MEDIUM HEAVY OIL / USA n° 4:  
basic version with 2800 rpm oil pump installed directly on fan motor shaft (see available codes in the table above)
- 2) PRESS P/N version for viscosity up to 20°E (150 mm<sup>2</sup>/s, cSt), Type BUNKER B / USA n° 5:  
as basic version + heavy oil heating cartridges factory installed on nozzle, pump and valves group (please ask for specific code)
- 3) PRESS P/N ECO version for viscosity up to 20°E (150 mm<sup>2</sup>/s, cSt), Type BUNKER B / USA n° 5:  
with separate 1400 rpm low speed pump, heavy oil heating cartridges factory installed on nozzle, pump and valves group (please ask for specific code)
- 4) PRESS P/N and PRESS P/N ECO versions for viscosity up to 60°E (450 mm<sup>2</sup>/s, cSt), Type BUNKER C / USA n° 6:  
as versions 2) or 3) with pipes heating cable factory installed (please ask for specific code)

### Special configuration on demand:

- Steam oil pre-heater on P/N ECO models.

# Modulating Heavy Oil Burners

## PRESS P/N - P/N ECO SERIES

### Burner accessories

Available for P/N and P/N ECO versions

#### Nozzles



The nozzles must be ordered separately. The following table shows the features and codes on the basis of the maximum required output.

NOTE: each burner needs N° 1 nozzle.

BURNER	RATED OUTPUT kg/h	NOZZLES BERGONZO B5 45°- WITH "AA" NEEDLE CODE	NOZZLES FLUIDICS W2 45°- WITH "AA" NEEDLE CODE
▶ P 140 P/N	70	3009203	3045426
▶ P 140 P/N	80	3009205	3045427
▶ P 140 P/N	90	3009207	3045428
▶ P 140 P/N - P 200 P/N	100	3009209	3045430
▶ P 140 P/N - P 200 P/N	125	3009211	3045432
▶ P 200 P/N - P 300 P/N	150	3009213	3045434
▶ P 200 P/N - P 300 P/N	175	3009215	3045436
▶ P 200 P/N - P 300 P/N	200	3009800	3045438
▶ P 200 P/N - P 300 P/N	225	3009801	3045440
▶ P 300 P/N - P 400 P/N	250	3009802	3045442
▶ P 300 P/N - P 400 P/N	275	3009803	3045444
▶ P 300 P/N - P 400 P/N	300	3009804	3045446
▶ P 450 P/N	325	3009805	3045448
▶ P 450 P/N	350	3009806	3045450
▶ P 450 P/N	375	3009807	3045452
▶ P 450 P/N	400	3009808	3045454
▶ P 450 P/N	425	3009809	3045455
▶ P 450 P/N	450	3009810	3045456

#### Spacer kit



If burner head penetration into the combustion chamber needs reducing, varying thickness spacers are available, as given in the list.

BURNER	SPACER THICKNESS S (mm)	KIT CODE
▶ P 140 P/N - P 200 P/N	102	3000722
▶ P 300 P/N	130	3000723
▶ P 450 P/N	130	3000751

#### Sound proofing box

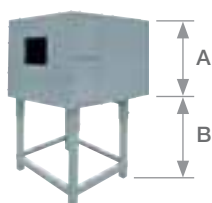

If noise emission needs reducing even further, sound-proofing boxes are available.

BURNER	BOX TYPE	A (mm)	B (mm) min-max	[dB(A)] (*)	BOX CODE
▶ P 140 P/N - P 200 P/N	C4/5	850	160 - 980	10	3010404
▶ P 300 P/N - P 450 P/N	C7	1255	160 - 980	10	3010376
▶ P 140 - 200 - 300 - 450 T/N ECO	C7	1255	160 - 980	10	3010376

(\*) Average noise reduction according to EN 15036-1 standard

## Burner accessories

### Self-cleaning filter



For cleaning heavy oil from dirty particles and impurities, it is equipped with a thermostatic heater for oil with 60°E viscosity at 50°C.

FILTER TYPE	FILTERING DEGREE (µm)	FILTER CODE
▶ Ø = 1"1/2 (60°E at 50°C)	300	3010022

HEATER / THERMOSTAT TYPE	HEATER / THERMOSTAT CODE
▶ Thermostatic heater with LED	3010060
▶ Heater	3010061
▶ Thermostat (two-stage / regulable)	3010062

### Gas separator bottle



Gas separator bottle connects the burner oil circuit to the main ring circuit. It allows to recover heat in excess and discharge return circuit gas.

BURNER	CODE
▶ P 140 P/N - P 200 P/N	3000748
▶ P 300 P/N - P 450 P/N	3010012

### Heavy oil kit



Equipped with electrical heaters, it permits the employment of PRESS P/N burners with fuel oil of max. viscosity at 50°C: 20°E (150 mm<sup>2</sup>/s, cSt), Type BUNKER B / USA n° 5.

BURNER	KIT CODE
▶ P 140 P/N - P 200 P/N - P 300 P/N - P 450 P/N	3000721

### Heavy oil precirculation kit



This kit, used with oil with high viscosity, maintains fuel circulation in the oil circuit for avoiding system stop at start up.

BURNER	KIT CODE
▶ P 140 P/N - P 200 P/N	3000749
▶ P 300 P/N - P 450 P/N	3000750

### Cartridge filter



For cleaning heavy oil from dirty particles and impurities, it is equipped with a cartridge system for oil with 7°E viscosity at 50°C.

BURNER	FILTER CODE
▶ P 140 P/N - P 200 P/N - P 300 P/N - P 450 P/N	3005209

# Modulating Heavy Oil Burners

## PRESS P/N - P/N ECO SERIES

### Burner accessories

#### Burner support

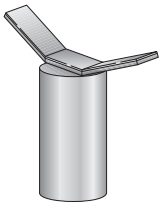

For easier maintenance, a mobile burner support has been designed, which means the burner can be dismantled without the need of forklift trucks.

BURNER	SUPPORT CODE
► P 300 P/N - P 450 P/N	3000731

#### Accessories for modulating operation



To obtain modulating operation, the PRESS P/N series of burners requires a regulator.

BURNER	REGULATOR TYPE	REGULATOR CODE
► P 140 P/N - P 200 P/N - P 300 P/N - P 450 P/N	RWF 40	3010211



The relative temperature or pressure probes fitted to the regulator, must be chosen on the basis of the application.

BURNER	PROBE TYPE	RANGE (°C) (bar)	PROBE CODE
► P 140 - 200 - 300 - 450 P/N	Temperature PT 100	-100 ÷ 500°C	3010110
► P 140 - 200 - 300 - 450 P/N	Pressure 4 ÷ 20 mA	0 ÷ 2,5 bar	3010213
► P 140 - 200 - 300 - 450 P/N	Pressure 4 ÷ 20 mA	0 ÷ 16 bar	3010214



Depending on the servomotor fitted to the burner, a three-pole potentiometer (1000 Ω) can be installed to check the position of the servomotor.

BURNER	POTENTIOMETER KIT CODE
► P 140 P/N - P 200 P/N - P 300 P/N - P 450 P/N	3010021

## PRESS P/NA - P/NA ECO SERIES

Heavy oil burner series P/NA is an evolution of the traditional heavy oil modulating burners P/N series.

The new range applies a different technology to replace the usual mechanical atomising (high pressure) by “assisted” air/steam atomising (feed pressure 5-8 bar) and taking the related advantages when burning heavy fuels (even vegetal oil).

The upgraded design has been introduced to meet even the worst fuel qualities and to reach anyway the best achievable combustion performance (lower particulate and NOx emissions).

The capacity range is suited to cover applications on steam generators designed for production from 1 to 6 tons/hr of steam or an equivalent capacity in case of other kind of boiler.

Reliable and smooth ignition is achieved by LPG pilot burner installed into the combustion head.

The control system includes all safety and operation interlocks, making possible the configuration compliance to the latest design norms on world-wide base (i.e. EN 267 – UL 296 – others), by the available options on request.



HEAVY OIL

P 140 P/NA	400/800 ÷ 1600 kW
P 200 P/NA	570/1140 ÷ 2280 kW
P 300 P/NA	683/1710 ÷ 3420 kW
P 450 P/NA	1140/2615 ÷ 5130 kW
P 140 P/NA ECO	400/800 ÷ 1600 kW
P 200 P/NA ECO	570/1140 ÷ 2280 kW
P 300 P/NA ECO	683/1710 ÷ 3420 kW
P 450 P/NA ECO	1140/2615 ÷ 5130 kW

### FIRING RATES

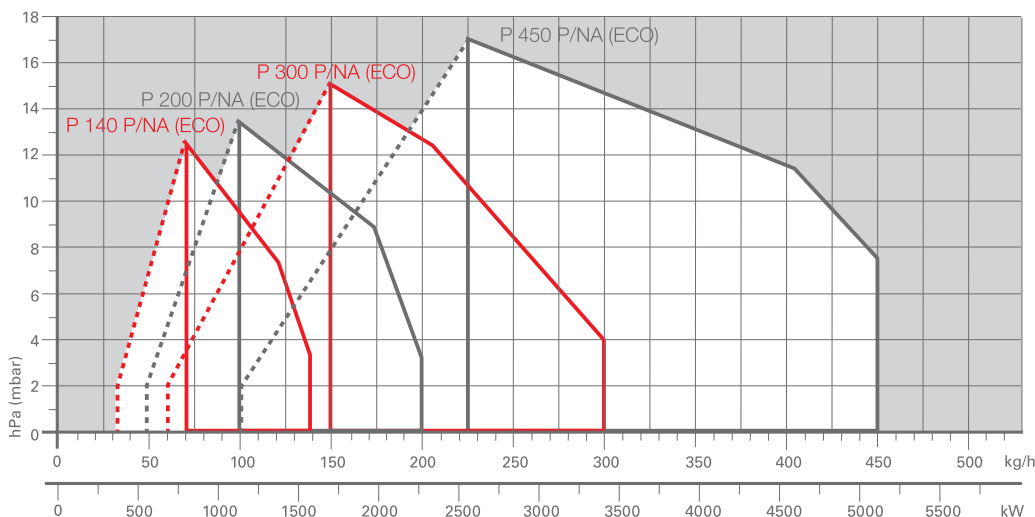

Useful working field for choosing the burner

Modulation range

Test conditions conforming to EN267  
 Temperature: 20°C  
 Pressure: 1013,5 mbar  
 Altitude: 0 m a.s.l.

# Modulating Heavy Oil Burners with Air/Steam Atomizing

## PRESS P/NA - P/NA ECO SERIES

### Overall dimensions (mm)

#### BURNER

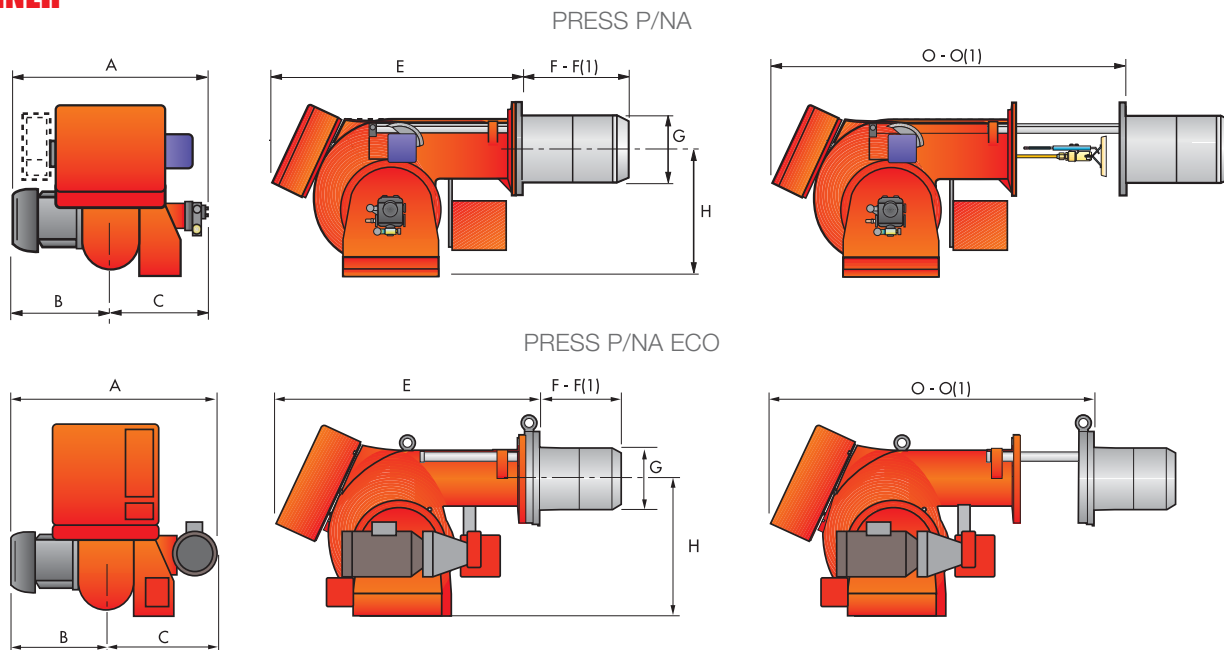

MODEL	A	B	C	E	F - F(1)	G	H	O - O(1)
▶ P 140 P/NA	796	396	400	910	323 - 433	222	467	1390 - 1390
▶ P 200 P/NA	796	396	400	910	352 - 462	250	467	1390 - 1390
▶ P 300 P/NA	858	447	411	1020	376 - 506	295	496	1535 - 1685
▶ P 450 P/NA	950	508	442	1090	435 - 565	336	525	1665 - 1820
▶ P 140 P/NA ECO	900	396	504	890	323 - 433	222	467	1370 - 1370
▶ P 200 P/NA ECO	900	396	504	890	352 - 462	250	467	1370 - 1370
▶ P 300 P/NA ECO	984	447	537	1000	376 - 506	295	496	1515 - 1665
▶ P 450 P/NA ECO	1100	508	592	1090	435 - 565	336	525	1665 - 1820

(1) Length with extended combustion head

#### BURNER - BOILER MOUNTING FLANGE

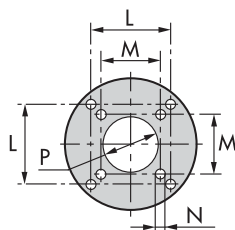

MODEL	L	M	N	P
▶ P 140 P/NA (ECO)	260	230	M 14	225
▶ P 200 P/NA (ECO)	260	-	M 16	255
▶ P 300 P/NA (ECO)	260	-	M 18	300
▶ P 450 P/NA (ECO)	310	-	M 20	350

#### PACKAGING

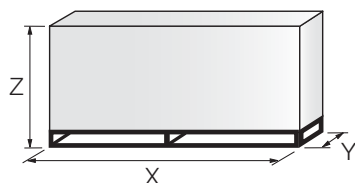

MODEL	X	Y	Z	kg
▶ P 140 P/NA (ECO)	1500	930	900	180
▶ P 200 P/NA (ECO)	1500	930	900	220
▶ P 300 P/NA (ECO)	1780	1085	990	238
▶ P 450 P/NA (ECO)	1780	1085	990	300

# Modulating Heavy Oil Burners with Air/Steam Atomizing

## PRESS P/NA - P/NA ECO SERIES

**RIELLO**

# Specification

## DESIGNATION OF SERIES

HEAVY OIL

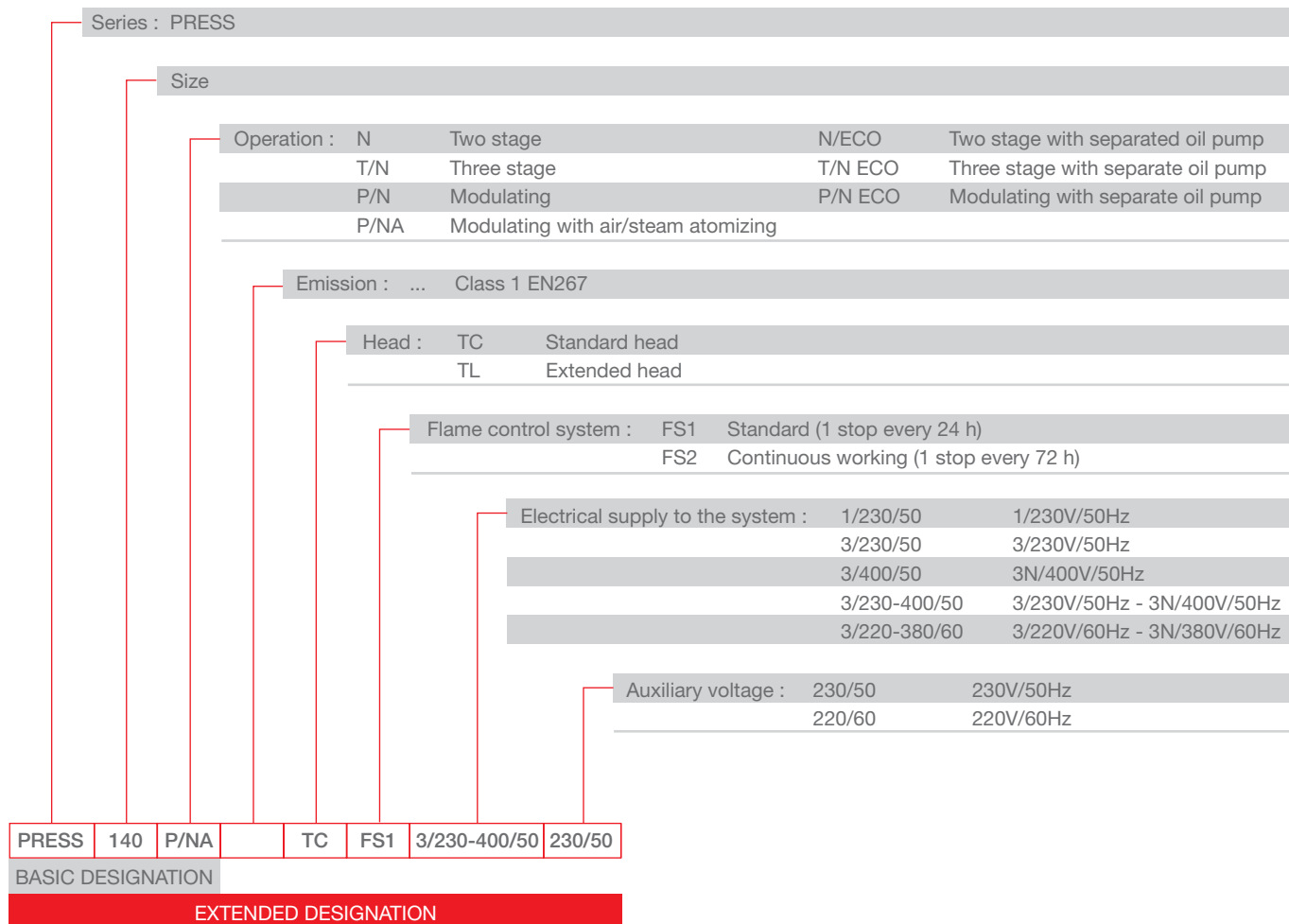

# Modulating Heavy Oil Burners with Air/Steam Atomizing

## PRESS P/NA - P/NA ECO SERIES

### Specification

#### STATE OF SUPPLY

Monoblock forced draught oil burner with two-stage progressive or modulating operation, with a specific kit, fully automatic, made up of:

- Air suction circuit lined with sound-proofing material
- Fan with forward curved blades high performance pressure levels
- Air damper for air setting and automatic oil output regulator controlled by a servomotor with variable cam
- Fan motor at 2850 rpm, three-phase 400V with neutral, 50Hz
- Combustion head, that can be set on the basis of the combustion output, fitted with:
  - stainless steel end cone, resistant to corrosion and high temperatures
  - ignition electrodes
  - flame stability disk
- Gears pump for high pressure fuel supply, fitted with:
  - filter
  - pressure regulator
  - connections for installing a pressure gauge and vacuumeter
  - internal by-pass for single pipe installation
- Heavy oil kit cartridges
- Pipes heating cable (P/NA ECO version)
- Oil pump motor at 1400 rpm (P/NA ECO version)
- Valve unit with a double oil safety valve on the output circuit
- LPG pilot burner ignition
- Electrical preheater for heavy oil
- Safety oil pressure switch
- Photocell for flame detection
- Burner safety control box, fitted with control function for the correct positioning of the servomotor and possibility of post-ventilaton by just changing the electric wiring
- Flame inspection window
- Slide bars for easier installation and maintenance
- Protection filter against radio interference
- IP X0D (IP 40) electric protection level.

#### Standard equipment:

- 2 flexible pipes for connection to the oil supply network
- 2 nipples for the connection to the pump
- Wiring looms fittings for electrical connections
- 4 screws for fixing the burner flange to the boiler
- 2 slide bar extensions (for the extended head models of P 300 P/NA and P 450 P/NA)
- Gasket for flange
- Starter\*
- Instruction handbook for installation, use and maintenance
- Spare parts catalogue.

\* for versions with star-delta starting



# Modulating Heavy Oil Burners with Air/Steam Atomizing

## PRESS P/NA - P/NA ECO SERIES

**RIELLO**

### Available models

CODE	MODEL					HEAT OUTPUT		TOTAL ELECTRICAL POWER (kW)	CERTIFICATION	NOTE
						(kW)	(kg/h)			
3808515	P 140 P/NA	TC	3/230-400/50	230/50	400/800-1600	33,7/67,4-134,9	11,5	-		
3808525	P 140 P/NA	TC	3/220-380/60	220/60	400/800-1600	33,7/67,4-134,9	11,5	-		
3808516	P 200 P/NA	TC	3/230-400/50	230/50	570/1140-2280	48/96,12-192,2	12,5	-		
3808526	P 200 P/NA	TC	3/220-380/60	220/60	570/1140-2280	48/96,12-192,2	12,5	-		
3808517	P 300 P/NA	TC	3/230-400/50	230/50	683/1710-3420	57,6/144,1-288,3	25	-		
3808527	P 300 P/NA	TC	3/220-380/60	220/60	683/1710-3420	57,6/144,1-288,3	25	-		
3808519	P 450 P/NA	TC	3/230-400/50	230/50	1140/2615-5130	96,1/220,5-432,6	37	-		
3808529	P 450 P/NA	TC	3/220-380/60	220/60	1140/2615-5130	96,1/220,5-432,6	37	-		

Net calorific value: 11,16 kWh/kg; 9600 kcal/kg

The burners of PRESS series are in according to 89/336 (2004/108) - 73/23 (2006/95) EC Directive and EN 267 Norm.

#### Viscosity

The modulating burner P/NA series can burn different heavy oil types from 50 up to 600 cSt @ 50°C (up to 80°E @ 50°C).

For different viscosity levels Riello recommends 3 different configurations:

- 1) PRESS P/NA version for viscosity up to 60°E (450 mm<sup>2</sup>/s, cSt), Type BUNKER C / USA n° 6:
  - with 2800 rpm oil pump installed directly on fan motor shaft
  - heavy oil heating cartridges factory installed on nozzle, pump and valves group  
(see available codes in the table above)
- 2) PRESS P/NA ECO version for viscosity up to 60°E (450 mm<sup>2</sup>/s, cSt), Type BUNKER C / USA n° 6:
  - with separate 1400 rpm low speed pump
  - heavy oil heating cartridges factory installed on nozzle, pump and valves group  
(please ask for specific code)
- 3) PRESS P/NA and PRESS P/NA ECO versions for viscosity up to 80°E (600 mm<sup>2</sup>/s, cSt), Type CHINESE OIL n° 60:
  - as versions 1) or 2) with pipes heating cable factory installed  
(please ask for specific code)

#### Special configuration on demand:

- Steam oil pre-heater on P/NA ECO models.

# Modulating Heavy Oil Burners with Air/Steam Atomizing

## PRESS P/NA - P/NA ECO SERIES

### Burner accessories

Available for P/NA and P/NA ECO versions

#### Y-jet air/steam atomising nozzles - type 15 AG 45°



Effective nozzle delivery depends from many factors. Particular small variations of air/steam atomising pressure or viscosity at the nozzle, cause big oil delivery variations. Therefore, to choose the right nozzle it is so necessary to consider all parameters listed in the table below.

NOZZLE 15 AG 45°	VISCOSITY @ NOZZLE	OIL DENSITY	OIL DELIVERY (kg/h)					AIR CONSUMPTION AT 4 bar (kg/h)		SUGGESTED AIR/ STEAM PRESSURE bar	CODE
			cSt	kg/m <sup>3</sup>	6 bar	5 bar	4 bar	3 bar	2 bar		
▶ 60	5	850	112	94	75	60	32	2,5	8,4	2	3045000
	10	875	95	80	60	41	20	5,9	13,9	3	
	20	900	75	60	42	25	n.a.*	10	20	4	
	30	925	68	55	36	20	n.a.*	11,3	21,7	4	
▶ 70	5	850	130	110	90	70	36	2,9	9,9	2	3045001
	10	875	111	95	78	48	25	6,8	16	3	
	20	900	88	70	50	30	n.a.*	11,9	23	4	
	30	925	80	64	44	24	n.a.*	13,2	25,4	4	
▶ 80	5	850	150	130	105	80	40	3,3	11,3	2	3045002
	10	875	127	108	85	55	30	7,8	18,3	3	
	20	900	100	80	55	35	n.a.*	13,6	26,2	4	
	30	925	91	73	51	30	n.a.*	15	28,9	4	
▶ 100	5	850	187	158	130	100	50	4,2	14	2	3045003
	10	875	158	135	100	70	35	9,8	22,8	3	
	20	900	126	105	70	40	n.a.*	17	32,7	4	
	30	925	114	91	65	35	n.a.*	18,8	34,2	4	
▶ 130	5	850	243	200	170	130	60	5,4	18,3	2	3045004
	10	875	206	173	130	95	40	12,7	29,7	3	
	20	900	163	131	90	55	n.a.*	22	42,6	4	
	30	925	148	118	82	45	n.a.*	24,4	47	4	
▶ 160	5	850	299	260	210	160	80	6,7	22,5	2	3045005
	10	875	253	215	170	115	50	15,7	36,5	3	
	20	900	201	161	115	65	n.a.*	27,1	52,4	4	
	30	925	182	145	102	58	n.a.*	30	57,9	4	
▶ 200	5	850	374	330	260	215	105	8,3	28,1	2	3045006
	10	875	317	270	215	145	60	19,6	45,7	3	
	20	900	252	203	140	85	n.a.*	33,9	65,5	4	
	30	925	228	182	120	70	n.a.*	37,5	72,4	4	
▶ 225	5	850	421	365	285	220	110	9,4	31,7	2	3045007
	10	875	357	311	240	160	70	22,1	51,4	3	
	20	900	280	225	156	100	n.a.*	38,2	73,7	4	
	30	925	256	205	141	60	n.a.*	42,2	81,4	4	
▶ 250	5	850	468	410	340	250	120	10,4	35,2	2	3045008
	10	875	396	340	270	180	80	24,5	57,1	3	
	20	900	315	252	175	110	n.a.*	42,4	81,9	4	
	30	925	285	228	150	85	n.a.*	46,8	90,5	4	
▶ 275	5	850	514	430	360	270	130	11,5	38,6	2	3045009
	10	875	436	365	300	190	85	27	62,8	3	
	20	900	346	277	193	120	n.a.*	46,7	90	4	
	30	925	313	250	175	95	n.a.*	51,6	99,5	4	
▶ 300	5	850	560	470	400	300	150	11,5	38,6	2	3045010
	10	875	476	410	340	200	90	29,3	68,5	3	
	20	900	378	302	210	130	n.a.*	51	98,2	4	
	30	925	342	273	190	100	n.a.*	56,3	108,6	4	

\* This matching is not available.

## Burner accessories

### Spacer kit



If burner head penetration into the combustion chamber needs reducing, varying thickness spacers are available, as given in the list.

BURNER	SPACER THICKNESS S (mm)	KIT CODE
► P 140 P/NA - P 200 P/NA	102	3000722
► P 300 P/NA	130	3000723
► P 450 P/NA	130	3000751

### Sound proofing box

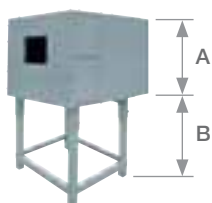

If noise emission needs reducing even further, sound-proofing boxes are available.

BURNER	BOX TYPE	A (mm)	B (mm) min-max	[dB(A)] (*)	BOX CODE
► P 140 P/NA - P 200 P/NA	C4/5	850	160 - 980	10	3010404
► P 300 P/NA - P 450 P/NA	C7	1255	160 - 980	10	3010376

(\*) Average noise reduction according to EN 15036-1 standard

### Self-cleaning filter



For cleaning heavy oil from dirty particles and impurities, it is equipped with a thermostatic heater for oil with 60°E viscosity at 50°C.

FILTER TYPE	FILTERING DEGREE (µm)	FILTER CODE
► Ø = 1"1/2 (60°E at 50°C)	300	3010022

HEATER / THERMOSTAT TYPE	HEATER / THERMOSTAT CODE
► Thermostatic heater with LED	3010060
► Heater	3010061
► Thermostat (two-stage / regulable)	3010062

### Cartridge filter



For cleaning heavy oil from dirty particles and impurities, it is equipped with a cartridge system for oil with 7°E viscosity at 50°C.

BURNER	FILTER CODE
► P 140 P/NA - P 200 P/NA - P 300 P/NA - P 450 P/NA	3005209

# Modulating Heavy Oil Burners with Air/Steam Atomizing

## PRESS P/NA - P/NA ECO SERIES

### Burner accessories

#### Gas separator bottle



Gas separator bottle connects the burner oil circuit to the main ring circuit. It allows to recover heat in excess and discharge return circuit gas.

BURNER	CODE
▶ P 140 P/NA - P 200 P/NA	3000748
▶ P 300 P/NA - P 450 P/NA	3010012

#### Burner support

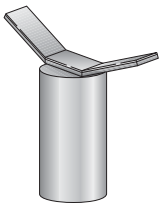

For easier maintenance, a mobile burner support has been designed, which means the burner can be dismantled without the need of forklift trucks.

BURNER	SUPPORT CODE
▶ P 300 P/NA - P 450 P/NA	3000731

#### Accessories for modulating operation



To obtain modulating operation, the PRESS P/NA series of burners requires a regulator.

BURNER	REGULATOR TYPE	REGULATOR CODE
▶ P 140 P/NA - P 200 P/NA - P 300 P/NA - P 450 P/NA	RWF 40	3010211



The relative temperature or pressure probes fitted to the regulator, must be chosen on the basis of the application.

BURNER	PROBE TYPE	RANGE (°C) (bar)	PROBE CODE
▶ P 140 - 200 - 300 - 450 P/NA	Temperature PT 100	-100 ÷ 500°C	3010110
▶ P 140 - 200 - 300 - 450 P/NA	Pressure 4 ÷ 20 mA	0 ÷ 2,5 bar	3010213
▶ P 140 - 200 - 300 - 450 P/NA	Pressure 4 ÷ 20 mA	0 ÷ 16 bar	3010214



Depending on the servomotor fitted to the burner, a three-pole potentiometer (1000 Ω) can be installed to check the position of the servomotor.

BURNER	POTENTIOMETER KIT CODE
▶ P 140 P/NA - P 200 P/NA - P 300 P/NA - P 450 P/NA	3010021

## Burner accessories

### Gas/LPG Pressure regulator and SSOV for pilot burner (inlet pressure 0,5-7 bar)



To be applied on gas/LPG bottle when not already available.

TYPE	CODE
▶ HPR 1910	3010405

### Air/steam pressure regulator

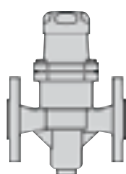

To be installed on the air/steam supply line according to supply system.

TYPE	CODE
▶ BRV	3010406

### Steam valve over 10 bar or 180°C



To be applied for pressure from 10 to 15 bar or temperature from 180°C to maximum 200°C.

TYPE	CODE
▶ ODE	on demand

### Water separator bottle



To be installed on the air/steam supply line in order to prevent water droplets to the nozzle supply.

TYPE	CODE
▶ WSB	on demand



## RN SERIES

The RN series of burners covers a firing range from 228 to 1481 kW, and has been designed for use in hot or superheater water boilers, hot air or steam generators, diathermic oil boilers.

Operation is "two stage"; the burners are fitted with an electronic device LED PANEL, which supplies Information about burner working.

All necessary components of hydraulic heavy-oil circuit are assembled in a separate structure, called BAG, for easy and fast installation.

Optimisation of sound emissions is guaranteed by the use of fans with forward curved blades and sound deadening material incorporated in the air suction circuit.

The elevated performance of the fans and combustion head, guarantee flexibility of use and excellent working at all firing rates.

The exclusive design ensures reduced dimensions, simple use and maintenance. A wide range of accessories guarantees elevated working flexibility.



RN 28	114/228 ÷	342 kW
RN 38	136/273 ÷	456 kW
RN 50	171/342 ÷	570 kW
RN 70	228/456 ÷	798 kW
RN 100	342/684 ÷	1140 kW
RN 130	456/912 ÷	1481 kW

## FIRING RATES

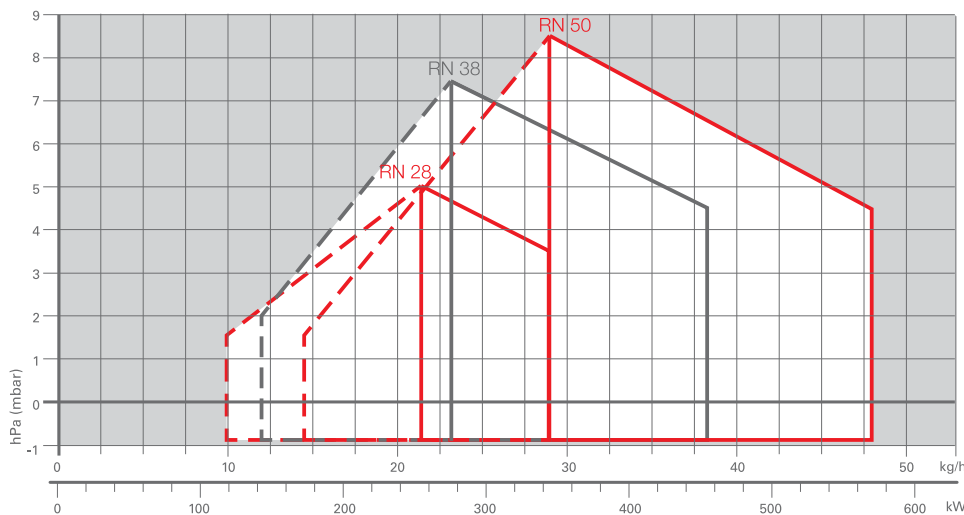

Useful working field for choosing the burner



1<sup>st</sup> stage operation range

Test conditions conforming to EN267  
 Temperature: 20°C  
 Pressure: 1013,5 mbar  
 Altitude: 0 m a.s.l.

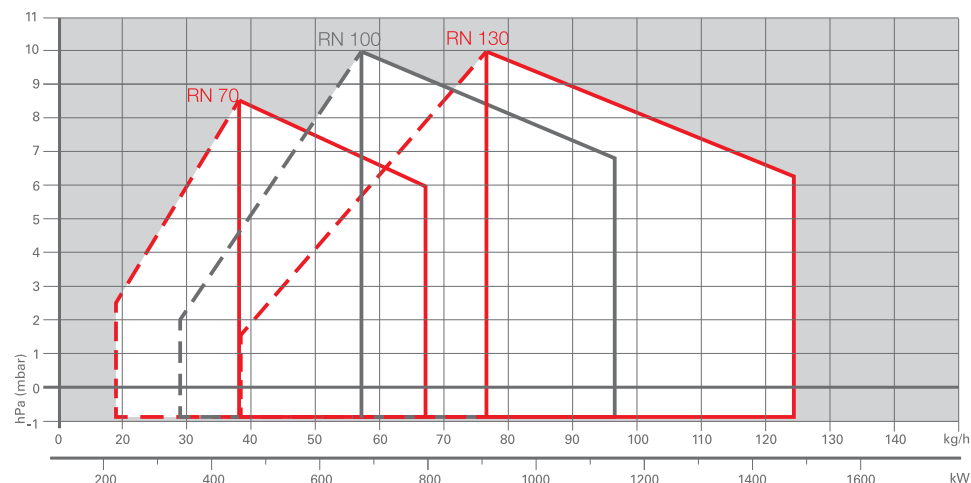

# Two Stage Heavy Oil Burners

## RN SERIES

### Overall dimensions (mm)

#### BURNER

RN 28 - 38 - 50

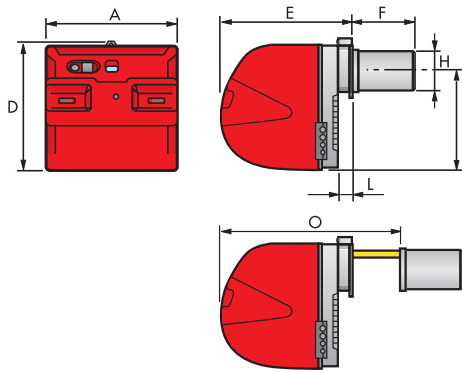

RN 70 - 100 - 130

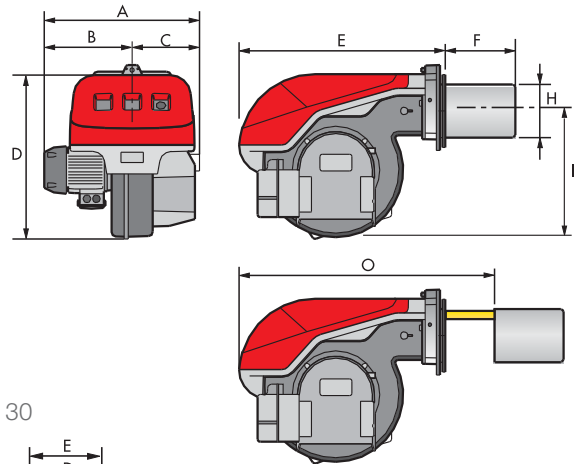

BAG 40 - 50 - 130

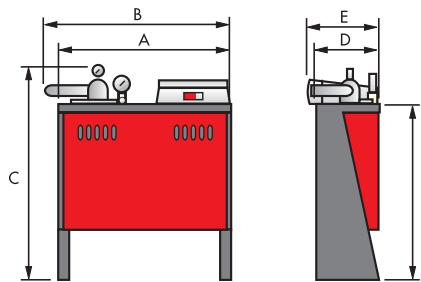

MODEL	A	B	C	D	E	F	H	I	L	O
▶ RN 28	476	-	-	474	468	265	166	352	52	730
▶ RN 38	476	-	-	474	468	265	166	352	52	730
▶ RN 50	476	-	-	474	468	265	166	352	52	730
▶ RN 70	511	296	215	555	680	310	189	430	-	951
▶ RN 100	527	312	215	555	680	330	200	430	-	951
▶ RN 130	553	338	215	555	680	330	220	430	-	951
▶ BAG 40 - 50 - 60	680	763	780	276	324	650	-	-	-	-

#### BURNER - BOILER MOUNTING FLANGE

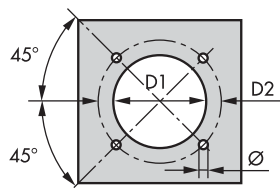

MODEL	D1	D2	Ø
▶ RN 28 - 38 - 50	170	224	M8
▶ RN 70	200	275-325	M12
▶ RN 100	210	275-325	M12
▶ RN 130	230	275-325	M12

#### PACKAGING

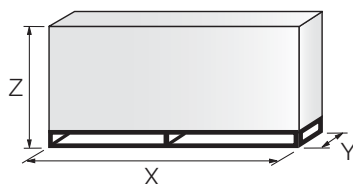

MODEL	X	Y	Z	kg
▶ RN 28	1015	630	500	52
▶ RN 38 - 50	1015	630	500	57
▶ RN 70	1054	614	666	59
▶ RN 100	1054	614	666	62
▶ RN 130	1054	614	666	65
▶ BAG 40	824	859	394	62
▶ BAG 50	824	859	394	67
▶ BAG 130	824	859	394	69



# Specification

## DESIGNATION OF SERIES

Series : R	
Fuel : S	Natural gas
L	Light oil
LS	Light oil / Natural gas
N	Heavy oil
Size	
Operation : /1	One stage
...	Two stage
/M	Modulating
/E	Electronic cam
/P	Proportioning air/gas valve
/EV	Electronic cam predisposed for variable speed (with inverter)
Emission : ...	Class 1 EN267 - EN676
MZ	Class 2 EN267 - EN676
BLU	Class 3 EN267 - EN676
MX	Class 2 EN267
	Class 3 EN676
Head : TC	Standard head
TL	Extended head
Diagnostic : LP	Led panel
ST	Status panel
Flame control system :	
FS1	Standard (1 stop every 24 h)
FS2	Continuous working (1 stop every 72 h)
Electrical supply to the system :	
1/230/50	1/230V/50Hz
3/230/50	3/230V/50Hz
3/400/50	3N/400V/50Hz
3/230-400/50	3/230V/50Hz - 3N/400V/50Hz
3/220/60	3/220V/60Hz
3/380/60	3N/380V/60Hz
3/220-380/60	3/220V/60Hz - 3N/380V/60Hz
Auxiliary voltage :	230/50-60      230V/50-60Hz
	110/50-60      110V/50-60Hz
ID :	Differential switch

R	N	50			TC	LP	FS1	3/230-400/50	230/50-60	
---	---	----	--	--	----	----	-----	--------------	-----------	--

BASIC DESIGNATION

EXTENDED DESIGNATION

# Two Stage Heavy Oil Burners

## RN SERIES

# Specification

### STATE OF SUPPLY

Monobloc forced draught heavy oil burner, two stage operation, made up of:

- Air suction circuit lined with sound-proofing material
- Fan with reverse curve blades
- Air damper for air setting controlled by a servomotor
- Combustion head, that can be set on the basis of required output
- Photocell for flame detection
- Burner safety control box
- Electronic device to check all burners operational modes (Led Panel)
- Burner on/off switch
- Manual 1st and 2nd stage switch
- Plugs for electrical connections (RN 28-38-50)
- Flame inspection window
- Slide bars for easier installation and maintenance
- Protection filter against radio interference
- IP 44 electric protection level.

### BAG

- Pressure gauge for fuel supply loop
- Atomising pressure gauge
- Self-controlling resistances for warming suction filter, delivery filter, valve and pump
- High and Low point thermostat
- High point thermostat with reset push-button
- Loop pressure control switch with burner operation enable (set at 1 bar)
- Pump
- Pump motor
- Pre-purge valve
- Degasing unit
- Valve for gas release from degasing unit
- Comb-filter at delivery
- Terminal strip
- Wiring looms
- Bag/Burner electrical connection socket
- Electronic thermostat
- Heating element Pt100
- Back pressure valve
- Comb-filter at pump suction
- Pre-heater.

### Standard equipment:

- 2 flexible hoses for burner/bag connection (L = 1.3 m)
- 1 insulation for flexible hoses
- 2 nipples for flexible hoses
- 1 insulating screen
- 4 screws for fixing the burner flange to the boiler
- Wiring looms for electrical connections (for RN 28-38-50 model)
- 1 tube for installing BAG on left (for RN 28-38-50 model)
- 2 nozzles
- Instruction handbook for installation, use and maintenance
- Spare parts catalogue.

# Two Stage Heavy Oil Burners

## RN SERIES

**RIELLO**

## Available models

CODE	MODEL						HEAT OUTPUT		TOTAL ELECTRICAL POWER (kW)	CERTIFICATION	NOTE
							(kW)	(kg/h)			
3433201	RN 28	TC	LP	FS1	3/230-400/50	230/50-60	114/228-342	10/20-30	4	-	
3433301	RN 38	TC	LP	FS1	3/230-400/50	230/50-60	136/273-456	12/24-40	5	-	
3433401	RN 50	TC	LP	FS1	3/230-400/50	230/50-60	171/342-570	15/30-50	6	-	
3434101	RN 70	TC	LP	FS1	3/230-400/50	230/50-60	228/456-798	20/40-70	10	-	
3434201	RN 100	TC	LP	FS1	3/230-400/50	230/50-60	342/684-1140	30/60-100	10	-	
3434301	RN 130	TC	LP	FS1	3/230-400/50	230/50-60	456/912-1481	40/80-130	11	-	
3891510	BAG 40								3	-	(1)
3891511	BAG 50								4	-	(2)
3891512	BAG 130								8	-	(3)

(1) For RN 28 burner.

(2) For RN 38-50 burners.

(3) For RN 70-100-130 burners.

Net calorific value: 11,16 kWh/kg; 9.600 kcal/kg - Max Viscosity at 50°C: 20°E (150 mm<sup>2</sup>/s, cSt), Type BUNKER B / USA n° 5.

The burners of RN series are in according to 89/336 (2004/108) - 73/23 (2006/95) EC Directive and EN 267 Norm.

# Two Stage Heavy Oil Burners

## RN SERIES

### Burner accessories

#### Nozzle



#### TYPE F80 PL 45°

The nozzles must be ordered separately. The following table shows the features and codes on the basis of the maximum required output.

NOTE: each burner needs N° 2 nozzles.

BURNER	RATED DELIVERY (kg/h) at 22,5 bar	GPH	NOZZLE CODE
▶ RN 28	11,3	2	3043121
▶ RN 28 - RN 38	12,7	2,25	3043131
▶ RN 28 - RN 38	14,1	2,5	3043141
▶ RN 38 - RN 50	16,9	3	3043151
▶ RN 50 - RN 70	19,7	3,5	3043161
▶ RN 50 - RN 70	22,5	4	3043171
▶ RN 70	25,3	4,5	3043181
▶ RN 70 - RN 100	28,1	5	3043191
▶ RN 70 - RN 100	33,4	6	3043211
▶ RN 100 - RN 130	39,4	7	3043231
▶ RN 100 - RN 130	47,8	8,5	3043261
▶ RN 130	53,4	9,5	3043271
▶ RN 130	59	10,5	3043301

#### TYPE F80 PL 60°

BURNER	RATED DELIVERY (kg/h) at 22,5 bar	GPH	NOZZLE CODE
▶ RN 28	9,8	1,75	3041112
▶ RN 28	11,3	2	3043122
▶ RN 28 - RN 38	12,7	2,25	3043132
▶ RN 28 - RN 38	14,1	2,5	3043142
▶ RN 38 - RN 50	16,9	3	3043152
▶ RN 50 - RN 70	19,7	3,5	3043162
▶ RN 50 - RN 70	22,5	4	3043172
▶ RN 70	25,3	4,5	3043182
▶ RN 70 - RN 100	28,1	5	3043192
▶ RN 70 - RN 100	33,4	6	3043212
▶ RN 100 - RN 130	39,4	7	3043232
▶ RN 100 - RN 130	47,8	8,5	3043262
▶ RN 130	53,4	9,5	3043272
▶ RN 130	59	10,5	3043302

#### Connection flange kit

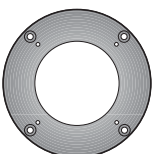

A kit is available for use where the burner opening on the boiler is of excessive diameter.

BURNER	KIT CODE
▶ RN 28 - RN 38 - RN 50	3010138